

16907



# STOP

# DO NOT RETURN TO THE STORE!

If you discover missing or damaged parts, or if you have questions about the building process, please reach out to us directly for the fastest service.

## 24/7 Support

[help.backyardproducts.com](http://help.backyardproducts.com)



- Answers to frequently asked questions
- Technical assistance and how-to videos
- Submit a help request
- Request replacement parts

## Business Hours

(734) 242-6900

Monday - Friday ..... 8:00am - 6:00pm EST

Saturday - Sunday .....Closed



Did you enjoy building your shed?

# JOIN OUR TEAM

AND MAKE UP TO \$1,500/WEEK\*

**Call a Recruiter Today! 734-365-7000**



Flexible schedule



No selling,  
just building



Bonus incentives  
available

\*based on number of completed installations

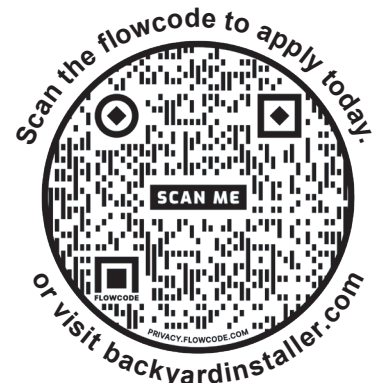

(This page intentionally left blank.)

**SALT BOX 8' x 6' (243,8 x 182,9 cm)**

ACTUAL FLOOR SIZE IS 96" x 72" (243,8 x 182,9 cm)

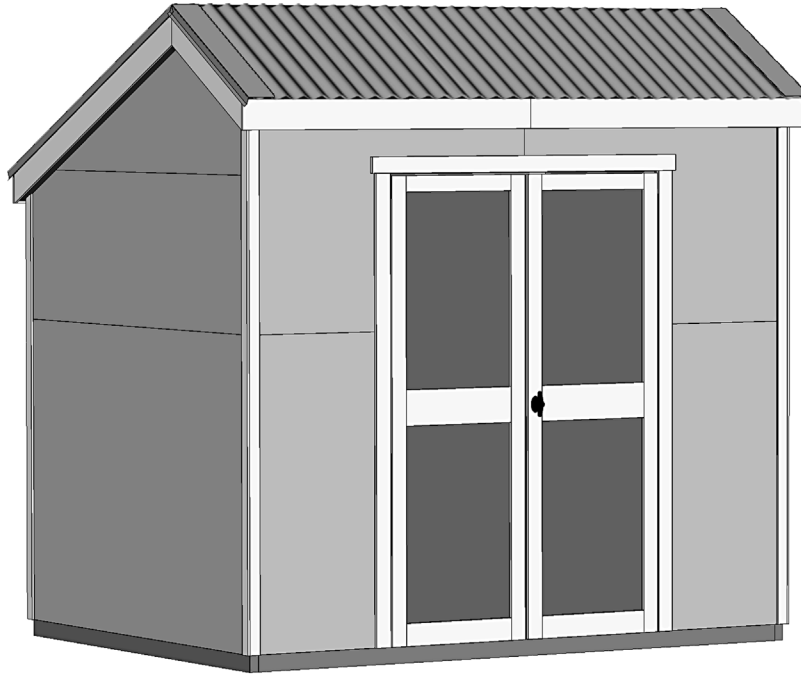
**KEEP THIS MANUAL FOR FUTURE REFERENCE****⚠ IMPORTANT! ⚠****READ INSTRUCTIONS THOROUGHLY PRIOR TO BEGINNING ASSEMBLY.****BEFORE YOU BEGIN****• BUILDING RESTRICTIONS AND APPROVALS**

Be sure to check local building department and homeowners association for specific restrictions and/ or requirements before building.

**• ENGINEERED DRAWINGS**

Contact our Customer Service Team if engineered drawings are needed to pull local permits.

**• SURFACE PREPARATION**

To ensure proper assembly you must build your shed on a level surface.

Recommended methods and materials to level your shed are listed on page 10.

**• CHECK ALL PARTS**

Inventory all parts listed on pages 4-7.









**• ADDITIONAL MATERIALS**

You will need additional materials to complete your shed. See page 3 for required and optional materials and quantities.

**\*\*\*CONTACT OUR CUSTOMER SERVICE TEAM  
IF ANY PARTS ARE MISSING OR DAMAGED\*\*\*****- Order form and warranty at back of manual -****Call: 1-734-242-6900 email: [customerservice@backyardproducts.com](mailto:customerservice@backyardproducts.com)**



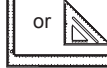

# TOOLS

## Required

- Phillips Screwdriver 
- Drill / Driver 
  - 1/4" Drill Bit
  - 3/8" Drill Bit
  - 1/2" Drill Bit
  - #2 Philips Drive Bit
- Hammer 
- Level 
- Pencil 
- Tape Measure 
- Square  or 

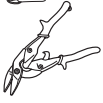
- Utility Knife 
  - Shingle Blades 
- Caulk Gun 
- Paint Tools 
- Safety Glasses 
- Ladder 

## Optional

- Tool Belt/ Nail Pouch 
- Tin Snips (for drip edge) 
- Pliers 
- Chalk Line 
- Nail Gun 
  - gun nails
- Gloves 

Safety! Always use approved safety glasses during assembly.

## HELPFUL REMINDER SYMBOLS

Look for these symbols for helpful reminders throughout this manual.



= Assistance Required; two or more people.



= Ensure squareness.



= Important required step or operation.



= Helpful assembly hint.



= Mark part with pencil.



**BEGIN** = Beginning of steps for assembly or installation.



**FINISH** = You have finished the assembly or installation.



= Level

## ORIENT LUMBER AND TRIM FOR BEST APPEARANCE

Framing lumber is graded for structural strength and not appearance. Exterior trim is graded for one good side.

Always install the material leaving the best edge and best surface visible. Please remember that these blemishes in no way negatively affect the strength or integrity of our product. (See Fig. A, B, C.)

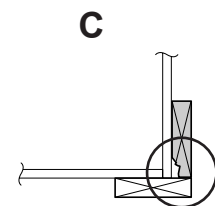
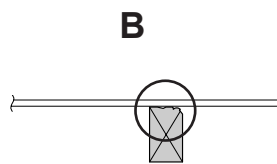
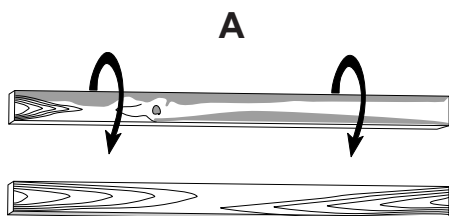

## ADDITIONAL MATERIALS

## FOUNDATION OR FLOOR MATERIALS

- A complete floor is supplied with this shed.
- See the FLOOR LEVELING section on page 10 for recommended methods and suggested materials to properly level your floor, as this will vary depending on your specific site.
- If you choose to install your floor on a concrete slab, refer to page 8.

## REINFORCED WOOD FLOOR FRAME (OPTIONAL)

**IMPORTANT!** Depending on your specific use you may want to construct a heavy duty floor frame by adding additional floor joists (shown below as shaded). Below is a list of additional materials (not included):

- x3** 2 x 4 x 8' (5 x 10 x 243,8 cm) Treated Lumber  
Cut to: 2 x 4 x 93" (5 x 10 x 236,2 cm)

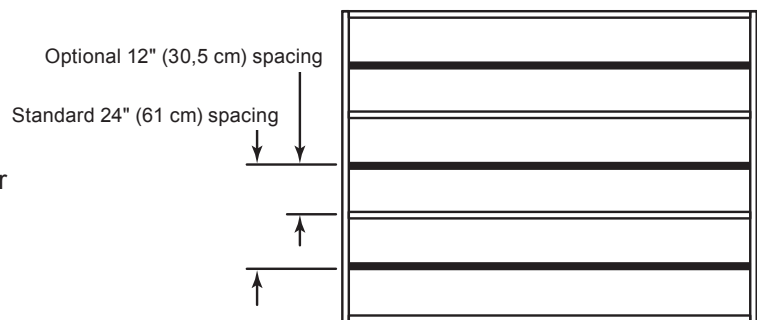

## COMPLETING YOUR SHED

You will need these additional materials:

- PAINT FOR SIDING** ..... **2 Gallons**  
Use 100% acrylic latex exterior paint. (2) coats recommended.

- PAINT FOR TRIM** ..... **2 Quarts**  
Use 100% acrylic latex exterior paint.

- CAULK** ..... **3 Tubes**  
Use acrylic latex exterior caulk that is paintable. 



**TO VALIDATE YOUR WARRANTY YOU MUST USE THE FOLLOWING:**



- RTV SILICONE** ..... **3 Tubes**  
For roof panel and ridge cap sealant  
Use neutral-cure RTV Silicone. 

## NAIL BOXES

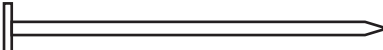
- x1** BOXES  3" (7,6 cm)
- x3** BOXES  2" (5,1 cm)

# PARTS IDENTIFICATION AND SIZES

Part identification letters are stamped on some parts.



Check these locations for part stamp.

Treated lumber is stamped:

**TREATED**

## WOOD SIZE CONVERSION CHART

Nominal Board Size	Actual Size
2 x 4	1-1/2" x 3-1/2" (3,8 x 8,9 cm)
1 x 4	3/4" x 3-1/2" (1,9 x 8,9 cm)
2 x 3	1-1/2" x 2-1/2" (3,8 x 6,3 cm)
1 x 3	3/4" x 2-1/2" (3,8 x 6,3 cm)

## PARTS LIST



**INVENTORY YOUR PARTS before you begin.**

We suggest sorting parts by the category they are listed in.

### WALLS

- x3 **PHB** 2 x 4 x 8-3/8" (5,1 x 10,2 x 21,3 cm)
- x2 **AO** 2 x 4 x 22-1/2" (5,1 x 10,2 x 57,1 cm)
- x2 **JBD** 2 x 4 x 20-3/8" (5,1 x 10,2 x 51,8 cm)
- x2 **UNB** 2 x 4 x 25-1/2" (5,1 x 10,2 x 64,8 cm)
- x2 **SC** 2 x 4 x 32" (5,1 x 10,2 x 81,3 cm)
- x8 **DMC** 2 x 4 x 44-3/4" (5,1 x 10,2 x 113,7 cm)
- x1 **TCA** 2 x 4 x 51" (5,1 x 10,2 x 129,5 cm)
- x2 **TKB** 2 x 4 x 59-1/4" (5,1 x 10,2 x 150,5 cm)
- x2 **PJ** 2 x 4 x 69" (5,1 x 10,2 x 175,3 cm)
- x2 **SHR** 2 x 4 x 70-3/8" (5,1 x 10,2 x 178,8 cm)
- x2 **RTJ** 2 x 4 x 70-1/2" (5,1 x 10,2 x 179,1 cm)
- x1 **TP** 2 x 4 x 96" (5,1 x 7,6 x 243,8 cm)
- x2 **OTV** **Tapered Profile** 2 x 4 x 96-3/4" (5,1 x 10,2 x 245,7 cm)
- x3 **RTC** **Tapered Profile** *Painted black on end* 2 x 4 x 96-3/4" (5,1 x 10,2 x 245,7 cm)
- x1 **UXA** 2 x 4 x 96-3/4" (5,1 x 10,2 x 245,7 cm)

### FLOOR

- x2 **TREATED** 2 x 4 x 72" (5,1 x 10,2 x 182,9 cm)
- x4 **TREATED** 2 x 4 x 93" (5,1 x 10,2 x 236,2 cm)

**NOTE:** Panels are *not stamped* for identification. Floor panels are 5/8" (1,6 cm) thick.

### FLOOR PANELS

- x1 5/8" x 48" x 96" (1,6 x 121,9 x 243,8 cm)

- x1 5/8" x 23-7/8" x 96" (1,6 x 60,6 x 243,8 cm)

# PARTS LIST

NOTE: Panels are *not stamped* for identification.

## WALL PANELS

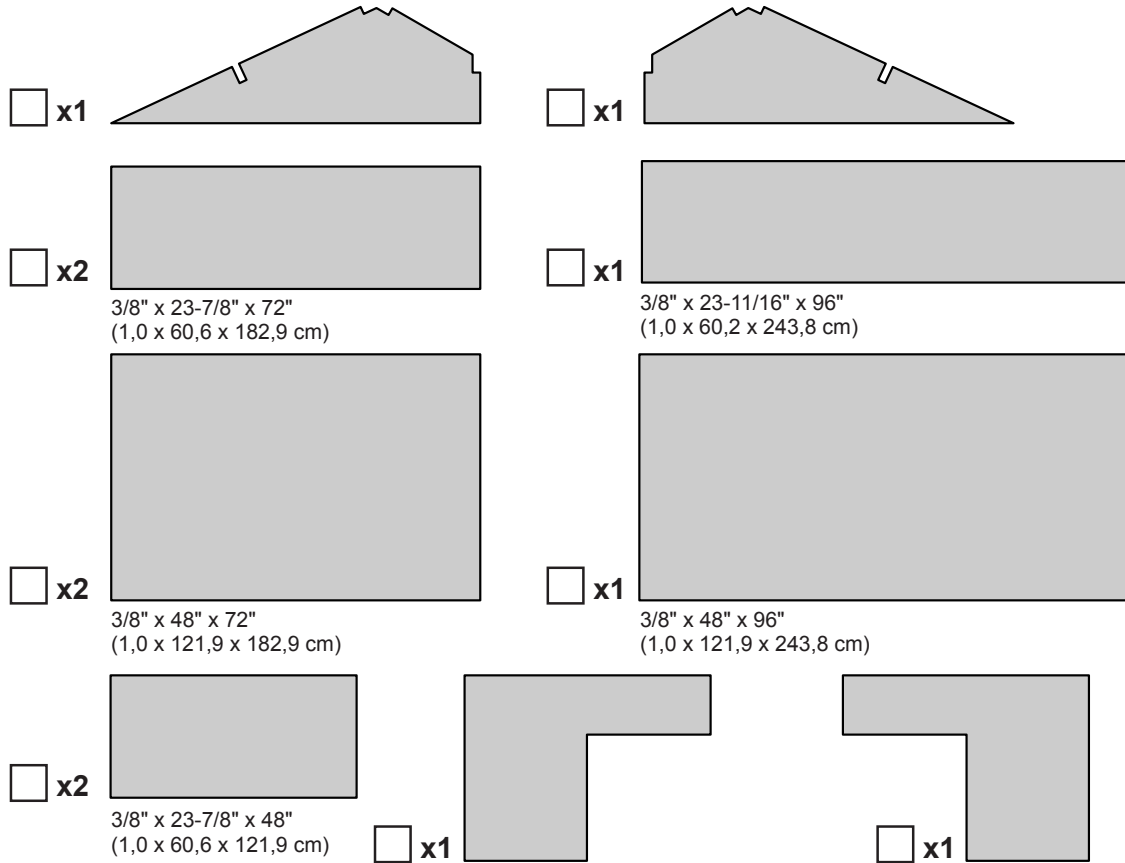

NOTE: Trim parts are *not stamped* for identification.

## TRIM & FASCIA

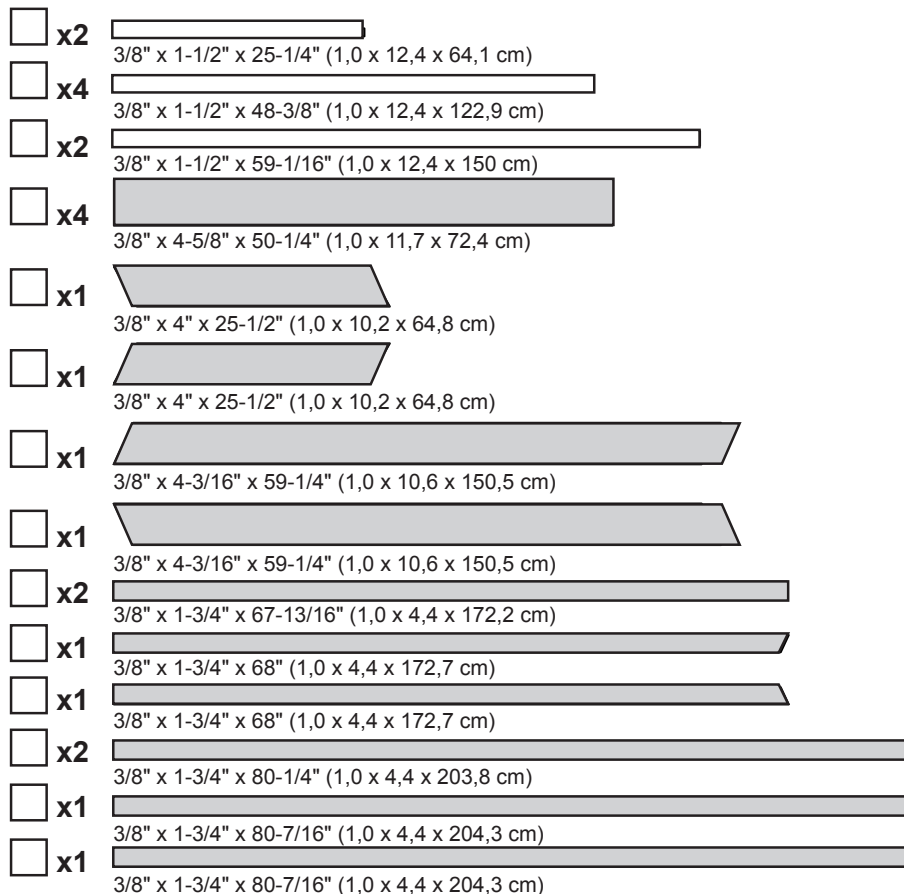

## DOORS

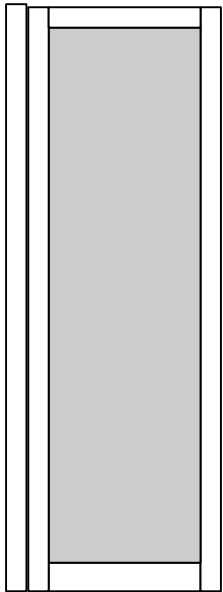

x1

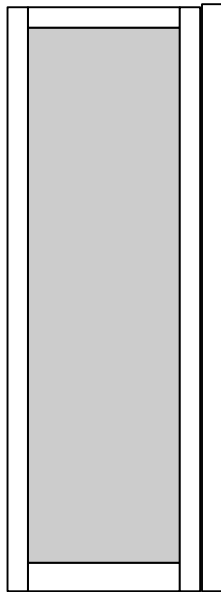

x1

x2 **WFB**

3/8" x 5-1/2" x 18-5/8" (1,0 x 14 x 47,3 cm)

x1 **JSA**

3/8" x 2-1/2" x 54-9/16" (1,0 x 8,9 x 138,6 cm)

x2 **OO**

69" Door Stiffener (175,3 cm)

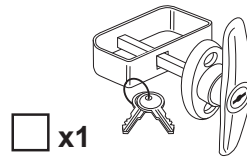

x2

1-1/2" (3,8 cm)

x1

**48" Metal Threshold**

3/4" (1,9 cm) x9  
Bagged seperately / special coating

x2

x8

1" (2,5 cm)

## FASTENER / HARDWARE BAG

x75 3" (7,6 cm)

x35 2" (5,0 cm)

x38 3/4" (1,9 cm)

x235 1-1/2" (3,8 cm)

x375 2" (5,1 cm)

**NOTE:**

*If you are using a nail gun, nails may be used where screws are shown for quicker assembly.*

*Length of nail must match screw length.*

## NAIL BOXES

x3 Boxes 2" (5,1 cm)

x1 Boxes 3" (7,6 cm)



## METAL TRIM / RAKE FLASHING

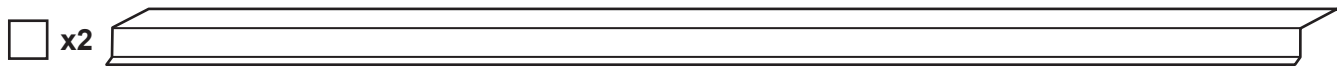

**Rake Flashing 15459** 1-1/4" x 93" (3,2 x 236,2 cm)

## ROOF PANELS & RIDGE CAP

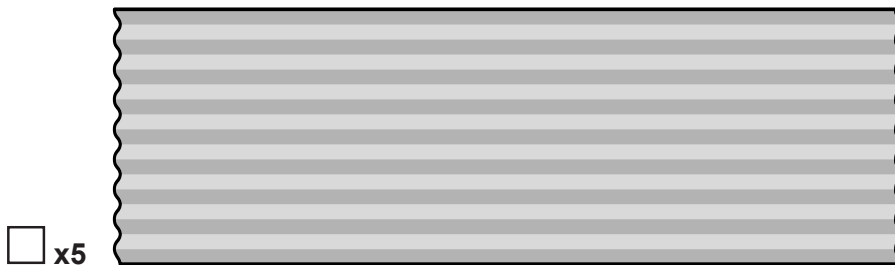

26" x 60" (66 x 152,4 cm)

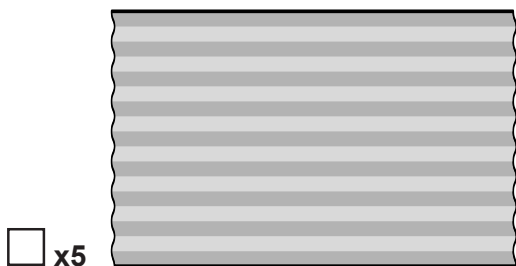

26" x 27" (66 x 68,6 cm)

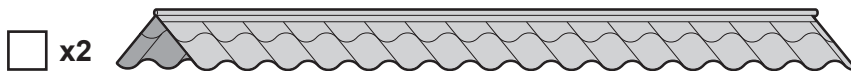

**Ridge Cap** 50" (127 cm)

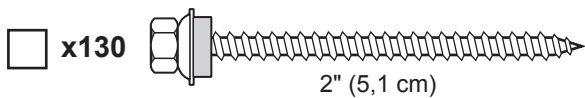
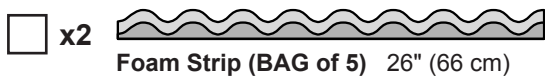

## CONCRETE FOUNDATION

If you choose to install your kit on a concrete slab refer to the diagram below.

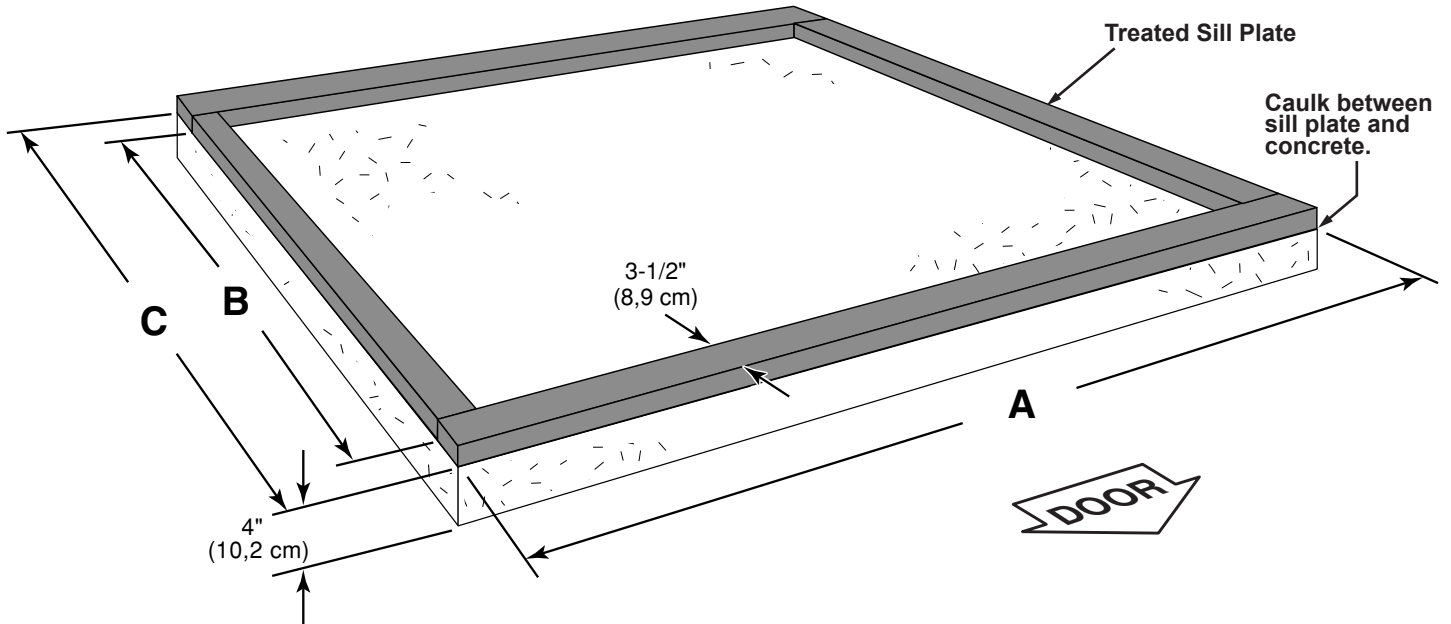

Building Size	Actual Size	A	B	C
8' x 6' (243,8 cm x 182,9 cm)	96" x 72" (243,8 cm x 182,9 cm)	96" (243,8 cm)	65" (165,1 cm)	72" (182,9 cm)

**Requires:**

- x4 2 x 4 x 8' (5,1 x 10,2 x 243,8 cm) **MUST be treated lumber.**  
Cut (2) down to: 2 x 4 x 65" (5,1 x 10,2 x 165,1 cm)
- x1 Caulk

Allow new concrete slabs to cure for at least seven (7) days.

• A treated 2 x 4 (5,1 x 10,2 cm) sill plate is required when installing your shed on concrete.  
**Hint: Purchase full length treated lumber.**

• Use a high quality exterior grade caulk beneath all sill plates.

• Fasten 2 x 4 (5,1 x 10,2 cm) sill plates to slab using approved concrete anchors (**fasteners not included**).

• Check local code for concrete foundation requirements.

### NOTES

---

---

---

---

---

---

---

---

---

---

# COMPONENT SECTION INDEX

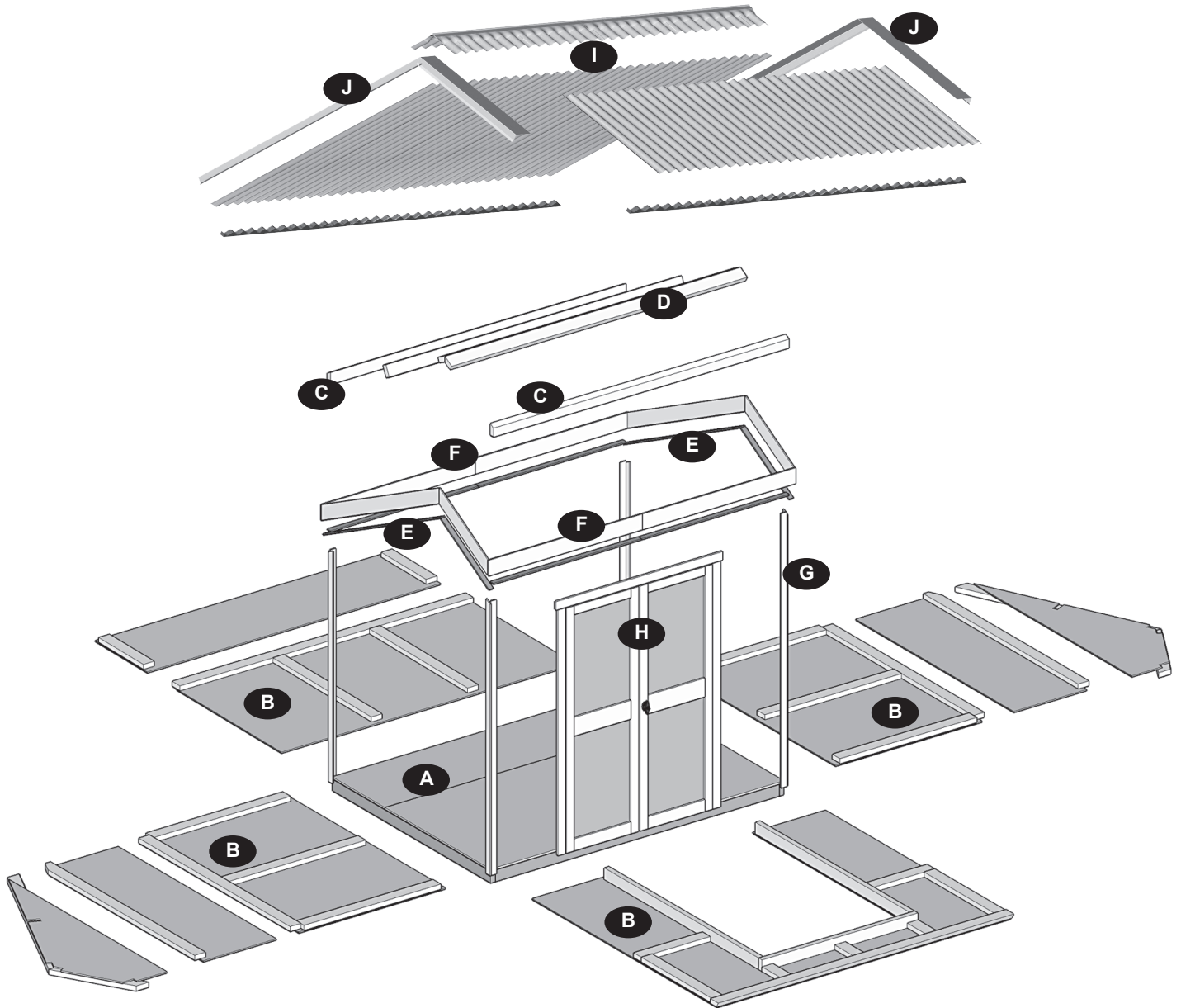

Description	Section	Page
Floor	A	11
Walls	B	15
Front & Back Overhang	C	32 & 33
Roof Framing	D	34
Soffit Trim	E	35
Fascia Trim	F	37
Corner Trim	G	38 & 45
Doors	H	39
Roof Panels/ Ridge Cap	I	46
Rake Flashing	J	55

## OPTIONAL WOOD FRAME FLOOR LEVELING OPTIONS

There are multiple ways to level your floor frame. Our recommended leveling method is shown below.  
*Leveling materials are not included in this kit.*

### PREFERRED METHOD - 4 x 4 TREATED RUNNERS (Typical for 8' x 6' Kit)

Runners are generally 12" (30,5 cm) from ends of floor frame and under seams.

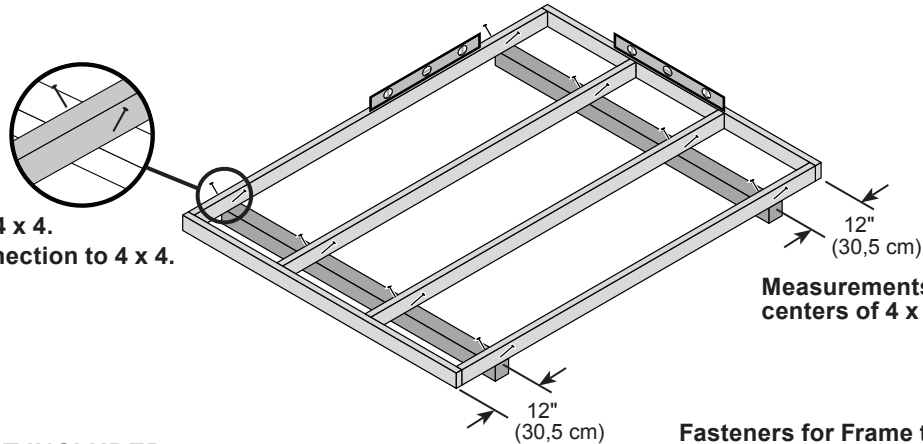

- 3" Screws angled into 4 x 4.
- (2) screws at each connection to 4 x 4.

Measurements to centers of 4 x 4's.

Fasteners for Frame to 4 x 4.  
 (3" Screws shown as one option.)  
 Minimum 3" screws / exterior grade.

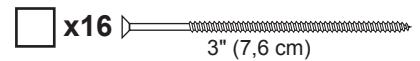

**! FLOOR FRAME NOT INCLUDED**

#### MATERIAL REQUIRED

**x2** 4 x 4 x 6' (10,2 x 10,2 x 182,9 cm) Treated Lumber

**! Use only wood treated for ground contact and fasteners approved for use with treated wood.**

**! Always support frame seams.**

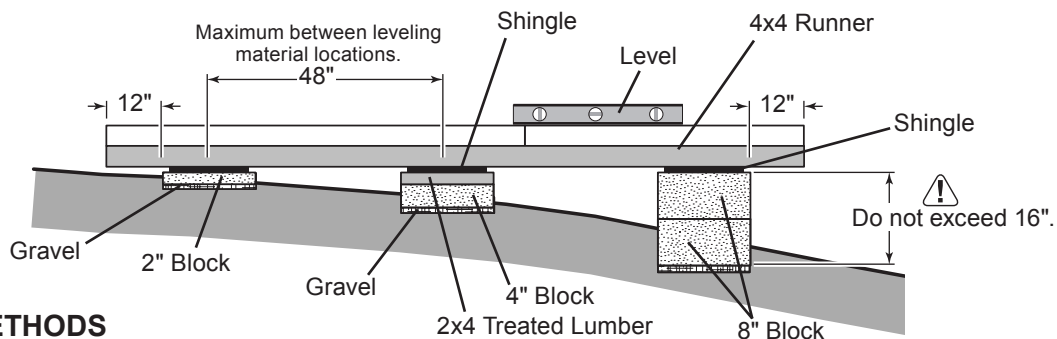

#### LEVELING METHODS

- Level under 4x4 runners only.
- Locate leveling material 12" from ends of runners and no more than 48" apart.
- Asphalt shingles should be used between 4x4 runners and blocks or treated lumber. Never use shingles in direct contact with ground.
- For best results and aiding in water drainage use gravel under each concrete block.

#### LEVELING MATERIALS

- Gravel
- Solid Masonry Blocks in 1", 2", 4" or 8" thickness
- 2x4 Treated Lumber
- Asphalt Shingles

**! Leveling higher than 16" not recommended.**

#### CONCRETE

- If you are building your shed on a concrete foundation see page 8.

# FLOOR FRAME

## PARTS REQUIRED:

**x4** 2 x 4 x 93" (5,1 x 10,2 x 236,2 cm)

**x2** 2 x 4 x 72" (5,1 x 10,2 x 182,9 cm)

Look for  
**TREATED**  
Stamp

**x16** 3" (7,6 cm)

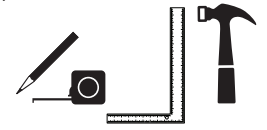

### ✓ BEGIN

- 1 Arrange parts as shown on flat surface. Measure and mark.  
Secure with (2) 3" nails at each mark.



**HINT:**  
For easier nailing  
stand on frame.

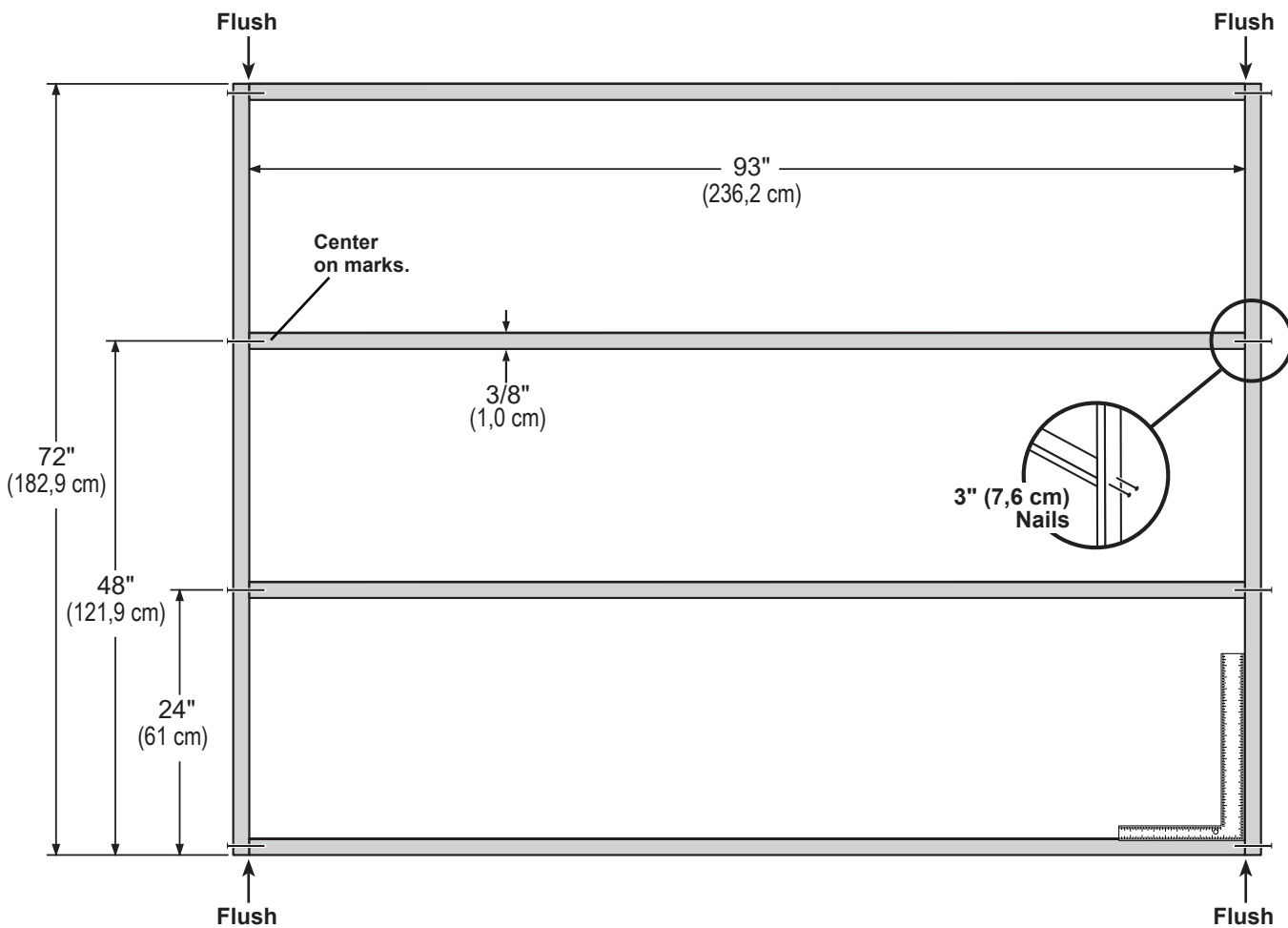
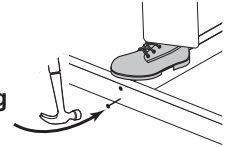

Your floor frame is now complete.

**STOP!**



## LEVEL AND SQUARE FLOOR FRAME



**STOP!**

Before attaching floor decking, it is important to level and square the floor frame. A level and square floor frame is required to correctly construct your shed.

**OPTIONAL 4x4 RUNNERS ARE NOT INCLUDED WITH THIS SHED**

**BEGIN**

- 1**  See page 9 for the preferred floor leveling method.
- 2** Use a level to ensure the frame is level before installing floor panels.
- 3** Check for frame squareness by measuring diagonally across corners. If the measurements are the same, the frame is square. The diagonal measurement will be approximately 120" (304,8 cm).
- 4** When the frame is level and square, secure one side of frame to the 4x4 runners using one fastener at ends of each runner. Move to the opposite end of the frame. Secure the frame to 4x4 runners with one fastener at ends of each runner, making sure the frame remains square.

**FINISH**

After the floor frame is level and square, fasten the frame to the 4x4 runners at each point where the frame contacts the 4x4 runners.

First, secure at ends with one fastener.

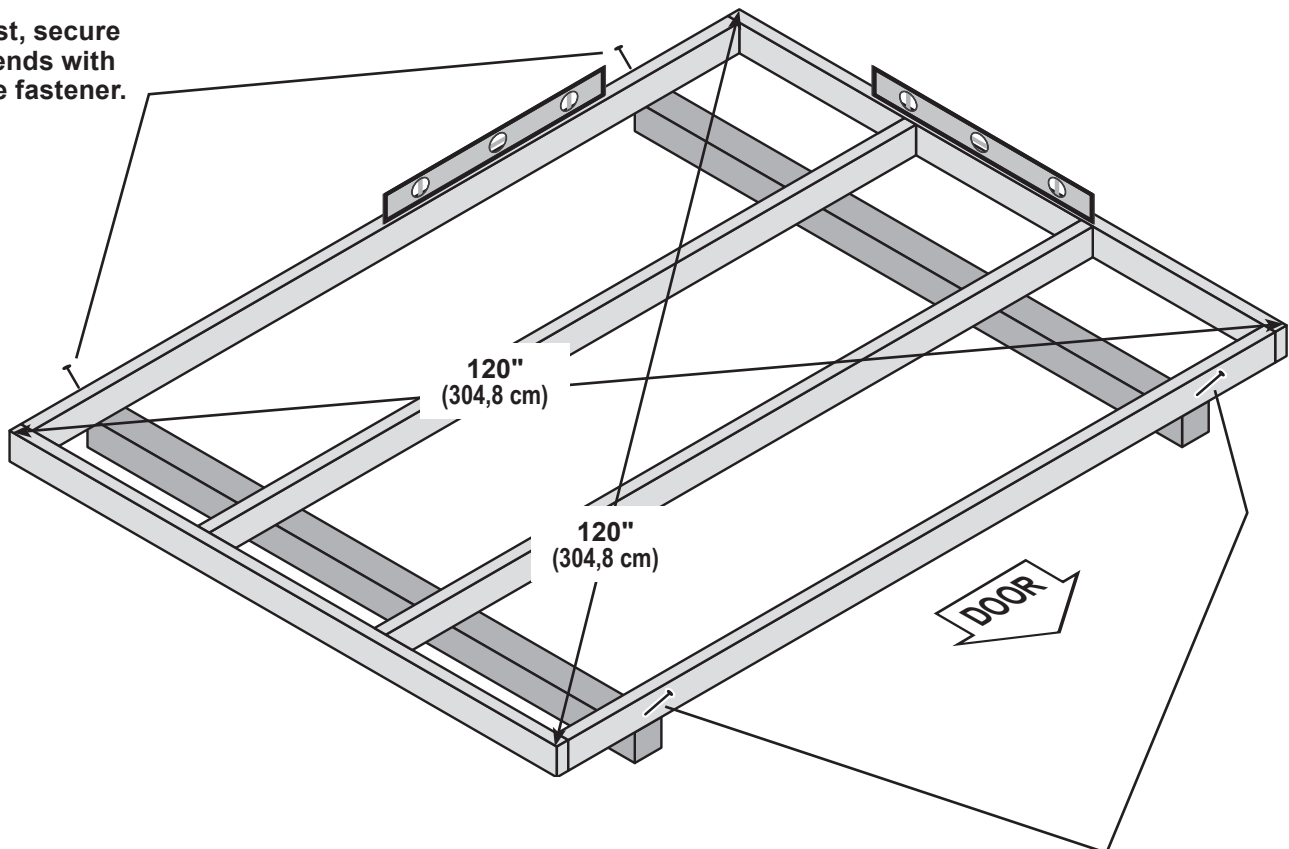

Second, secure at ends with one fastener.

# FLOOR PANELS

## PARTS REQUIRED:

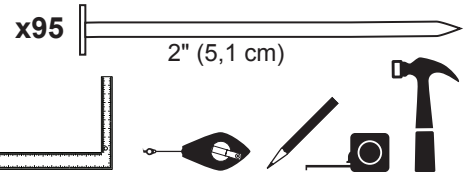
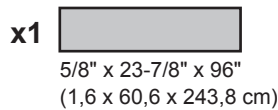

*Install panels with the rough side facing up (painted grid lines).*

### ✓ BEGIN

**1** Install the **48" x 96"** panel with the 48" edge and corner flush to the floor frame (**Fig A**).  
Ensure 3/4" measurement on the frame. Secure panel with (2) 2" nails in the corners.

**2** Move to the opposite side. Using the long edge of the panel as a lever, move the panel side-to-side until the corner is flush to the floor frame and (**Fig. B**).  
Ensure 3/4" measurement on the frame.  
Secure panel with (2) 2" nails in the corners.

**3** Install the **23-7/8" x 96"** panel flush to installed panel and flush to the floor frame.  
Secure panel with (1) 2" nail in each corner.

Fig. A

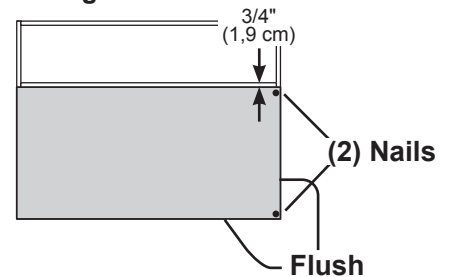
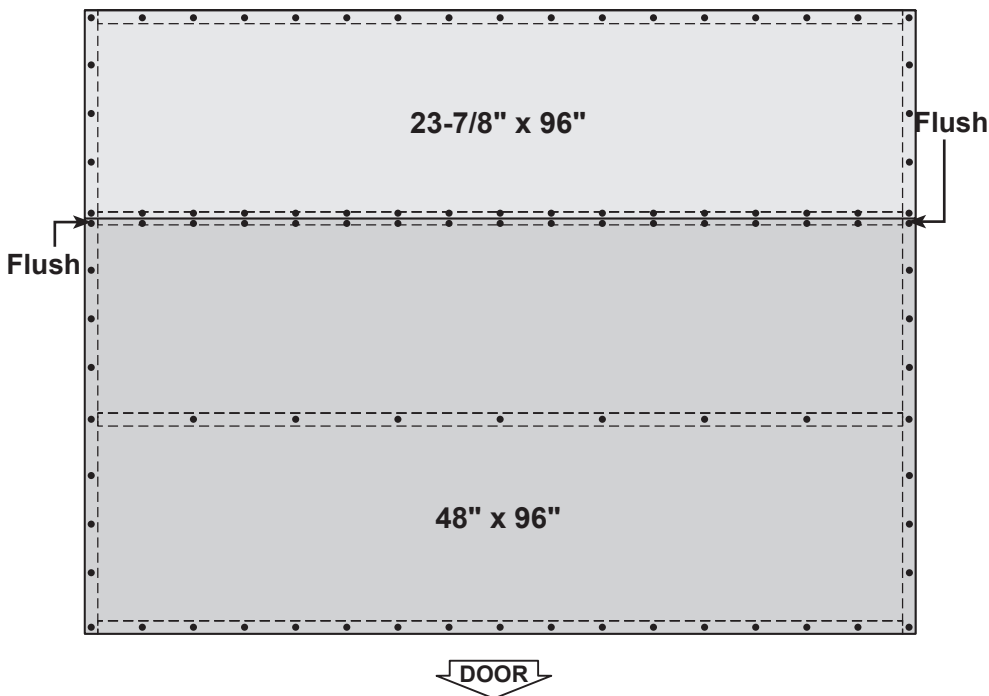
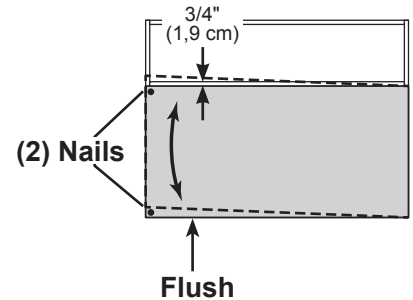

Fig. B



**4** Continue securing the panels with 2" nails spaced 6" apart on edges and 12" apart inside panels.



Your floor is now assembled.

## IMPORTANT!

**STOP!**

Check that the floor frame is level after installing floor panels.  
Re-level if needed.

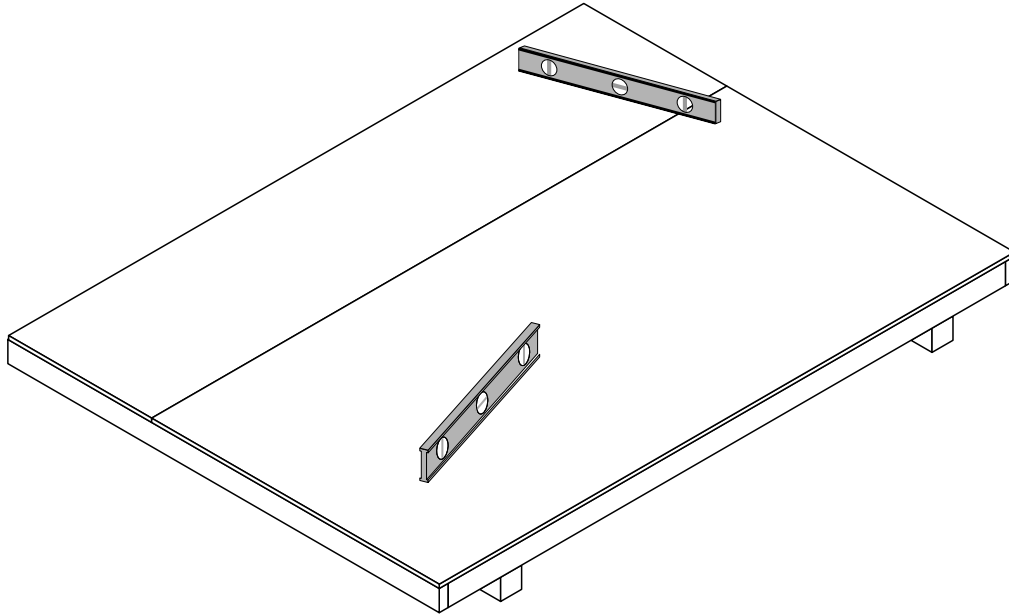

**HINT:**

- The floor should be used as a level work surface for wall construction.
- Organize your wall sections during sub-assembly to avoid over-handling of the walls.

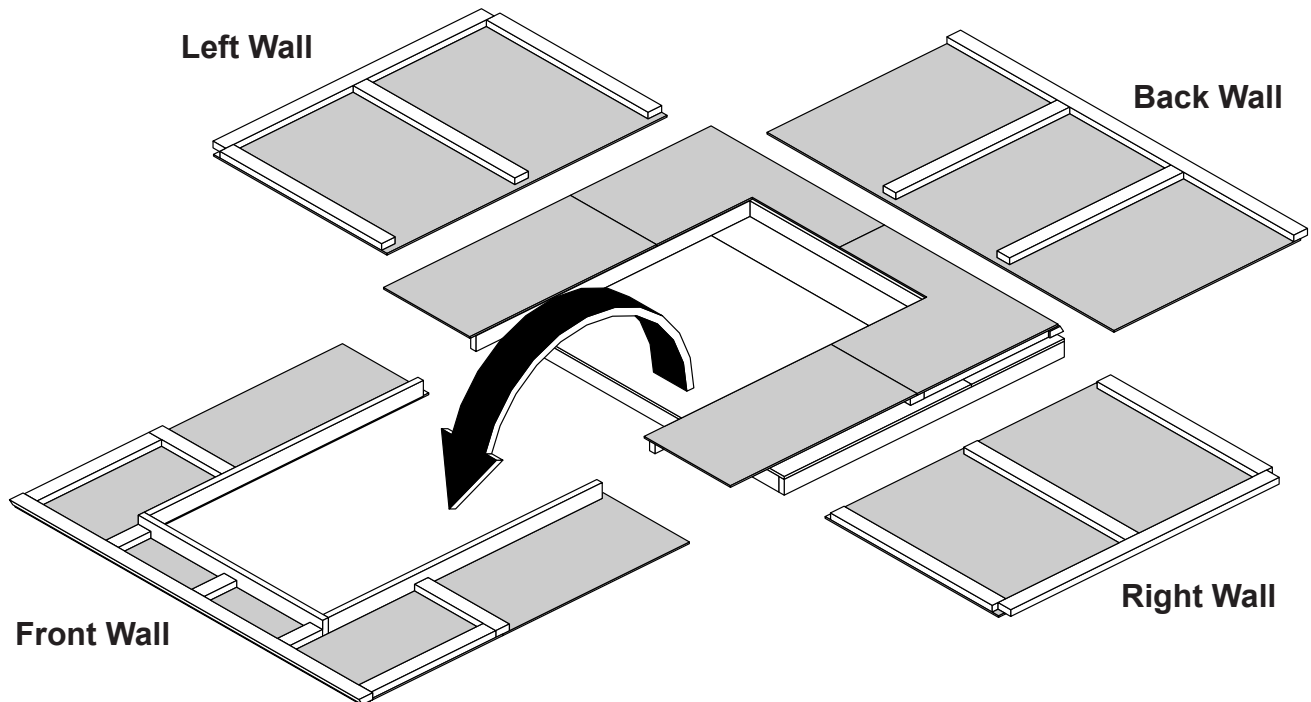





# SIDE WALLS

## PARTS REQUIRED:

**x8 DMC**  
2 x 4 x 44-3/4" (5,1 x 10,2 x 113,7 cm)

**x2 PJ**  
2 x 4 x 69" (5,1 x 10,2 x 175,3 cm)

**x2**  48 x 72"  
(121,9 x 182,9 cm)

**x4**  3" (7,6 cm)

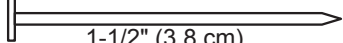
**x72**  1-1/2" (3,8 cm)

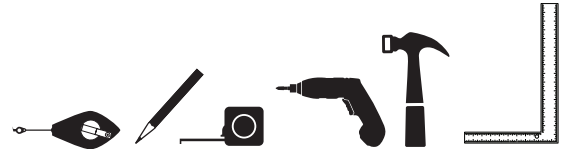

### Build 2 identical side walls.

#### ✓ BEGIN

**1**  
Arrange **DMC** and **PJ** on flat on floor.  
Center parts and mark.

Secure with (2) 3" screws at an angle.

*Predrill holes with 1/8" bit.*

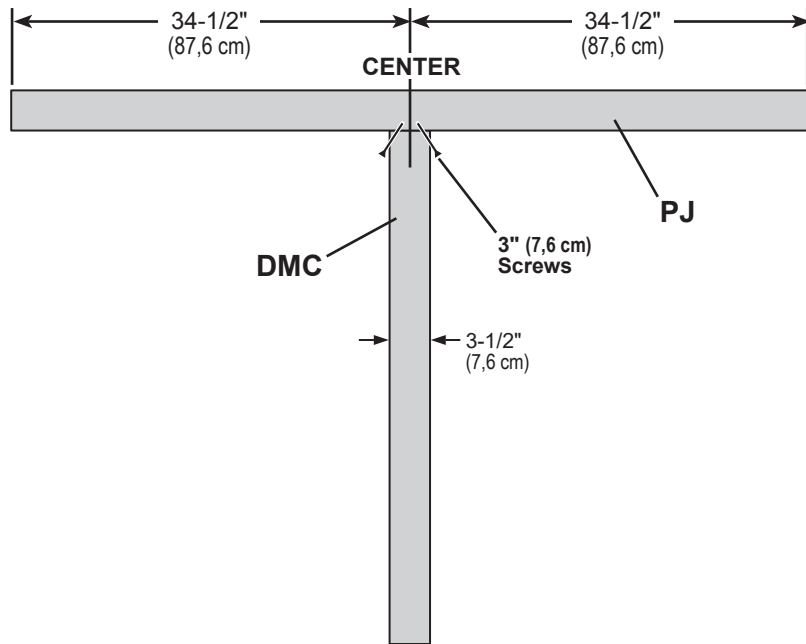

**2**  
Arrange (2) **DMC** on flat on floor,  
as shown.  
Measure 1-3/4" from edge of **PJ**  
and mark at each side.

Place **48" x 72"** panel over parts  
and at measurement on **PJ**.

Flush **DMC** to **PJ** and along edges  
of panel.

Secure panel to 2x4 parts with  
1-1/2" nails spaced 6" apart along  
edges and 12" apart in panel  
center.

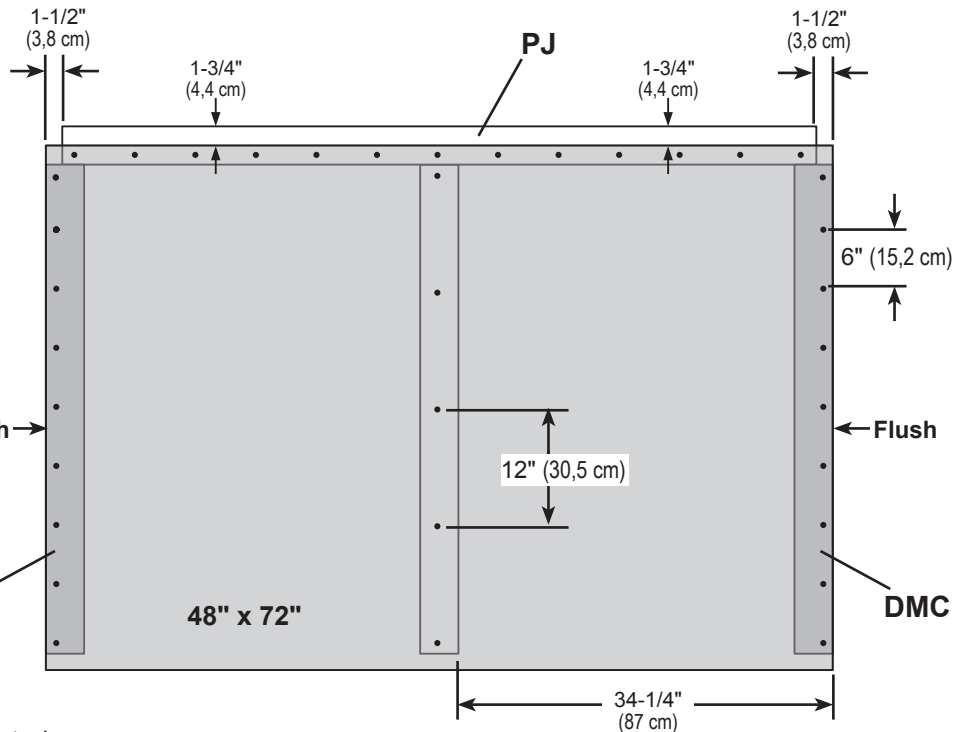

*Repeat steps to build the 2nd  
side wall.*



Your (2) lower side walls are now constructed.

# BACK WALL PREASSEMBLIES

## PARTS REQUIRED:

x2 **DMC**  
2 x 4 x 44-3/4" (5,1 x 10,2 x 113,7 cm)

x2 **JBD**  
2 x 4 x 20-3/8" (5,1 x 10,2 x 51,8 cm)

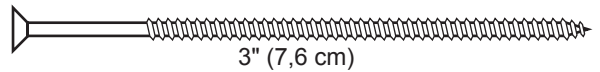
x4  3" (7,6 cm)

x1 **TP**  
2 x 4 x 96" (5,1 x 7,6 x 243,8 cm)

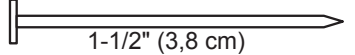
x35  1-1/2" (3,8 cm)

x1  48 x 96"  
(121,9 x 243,8 cm)

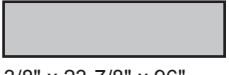
x1  3/8" x 23-7/8" x 96"  
(1,0 x 60,6 x 243,8 cm)

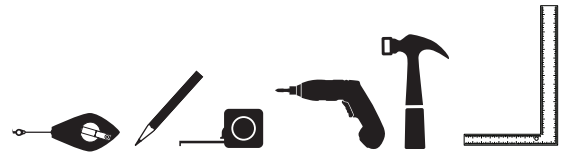

### BEGIN

**1**  
Arrange **DMC** and **TP** on flat on floor.  
Center parts and mark.  
Secure with (2) 3" screws at an angle.  
*Predrill all screw-holes with 1/8" bit.*

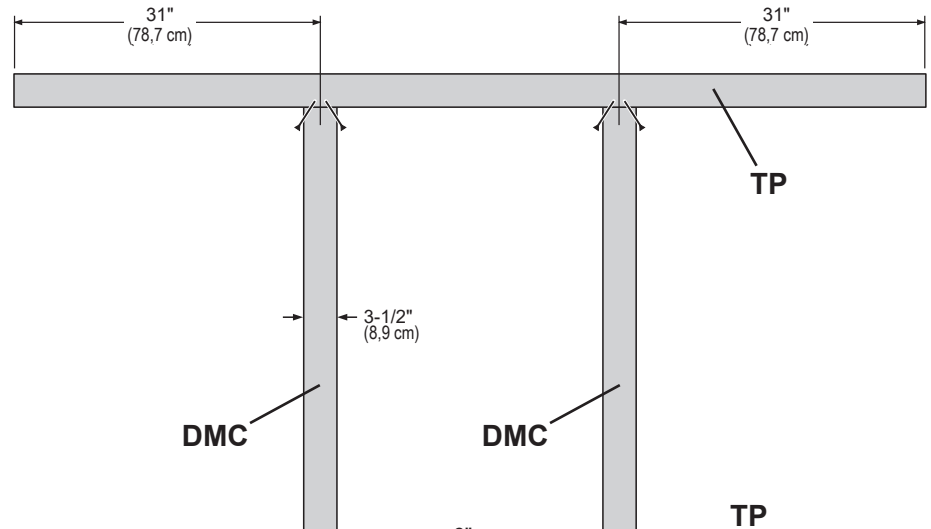

**2**  
Measure 1-1/4" from edge of **TP** and mark at each side.  
  
Place **48" x 96"** panel over parts and at measurement on **TP**: 1-3/4".  
Flush panel to ends of **TP**.

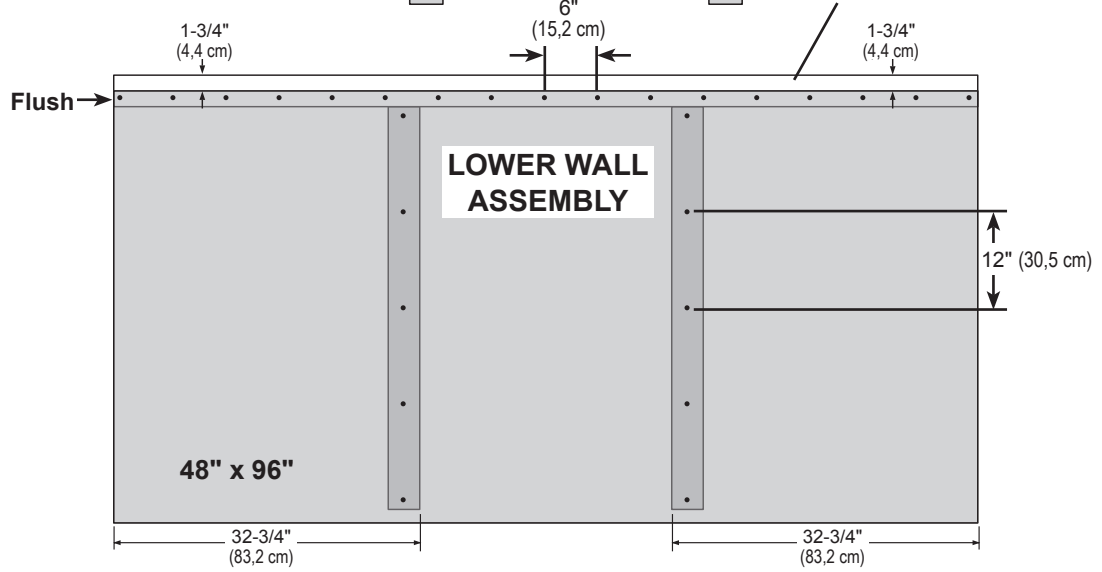

Check measurement to center of each **DMC**: (31").  
  
Secure panel to 2x4 parts with 1-1/2" nails spaced 6" apart along **TP** and 12" apart in panel center.

**3**  
Arrange (2) **JBD** on flat on floor.  
Place **48" x 96"** panel (*with primed side facing up*) over parts and at the measurement of 1-3/4".  
Flush **JBD** to panel edges.

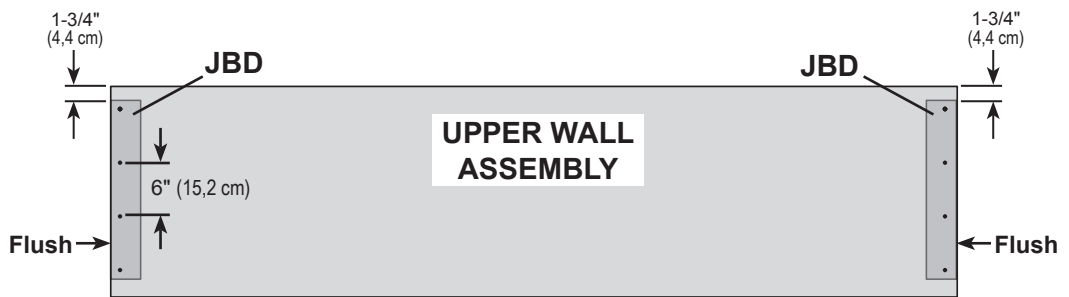

Secure panel with 1-1/2" nails spaced 6" apart.



Your lower and upper back wall sub-assemblies are now constructed.

# FRONT WALL UPPER FRAME

## PARTS REQUIRED:

- x3 **PHB**  
2 x 4 x 8-3/8" (5,1 x 10,2 x 21,3 cm)
- x2 **SC**  
2 x 4 x 32" (5,1 x 10,2 x 81,3 cm)
- x2 **AO**  
2 x 4 x 22-1/2" (5,1 x 10,2 x 57,1 cm)
- x1 **RTC** **Tapered Profile**  *Painted black on end*  
2 x 4 x 96-3/4" (5,1 x 10,2 x 245,7 cm)

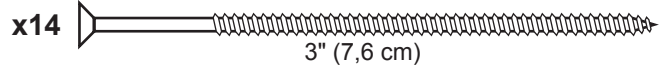

### ✓ BEGIN

- 1 Arrange parts on flat-side on floor. Measure and mark.  
Ensure profile angle of **RTC** is correct and ensure there is a 3/8" measurement at each end of **TPC**.  
Secure with (2) 3" screws at an angle. **Predrill all holes.**

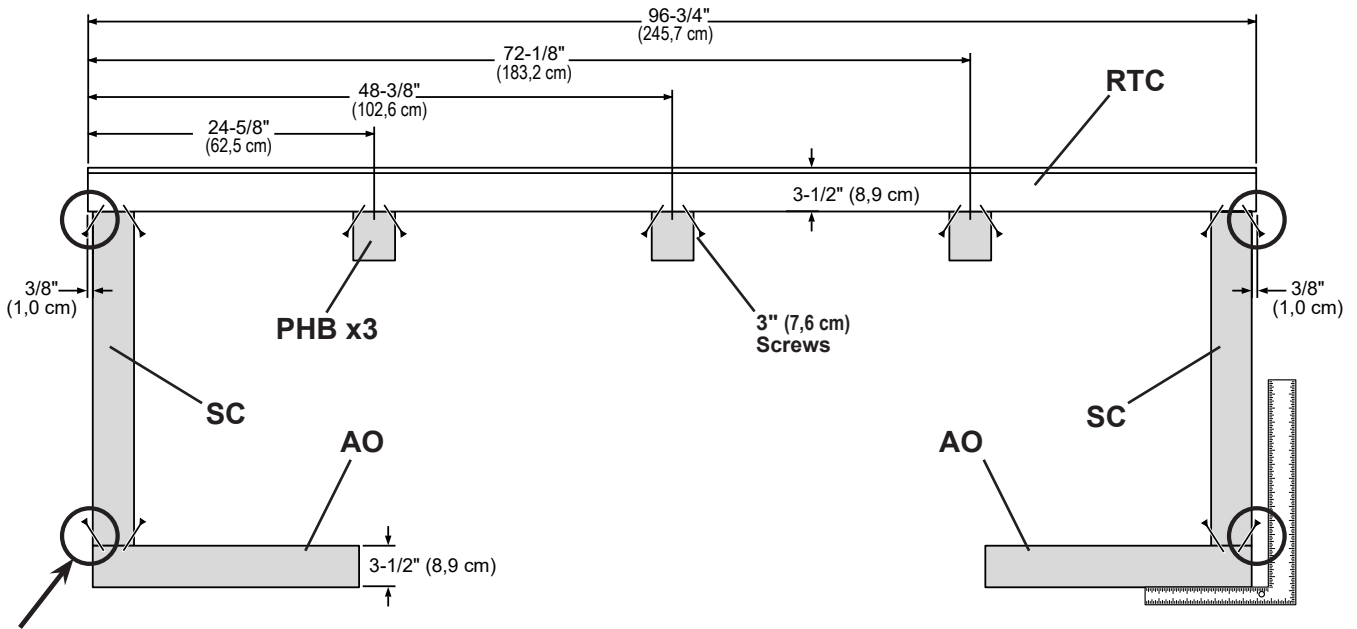

**NOTE:** Ensure outer screws are screwed-in flush to face of wood.

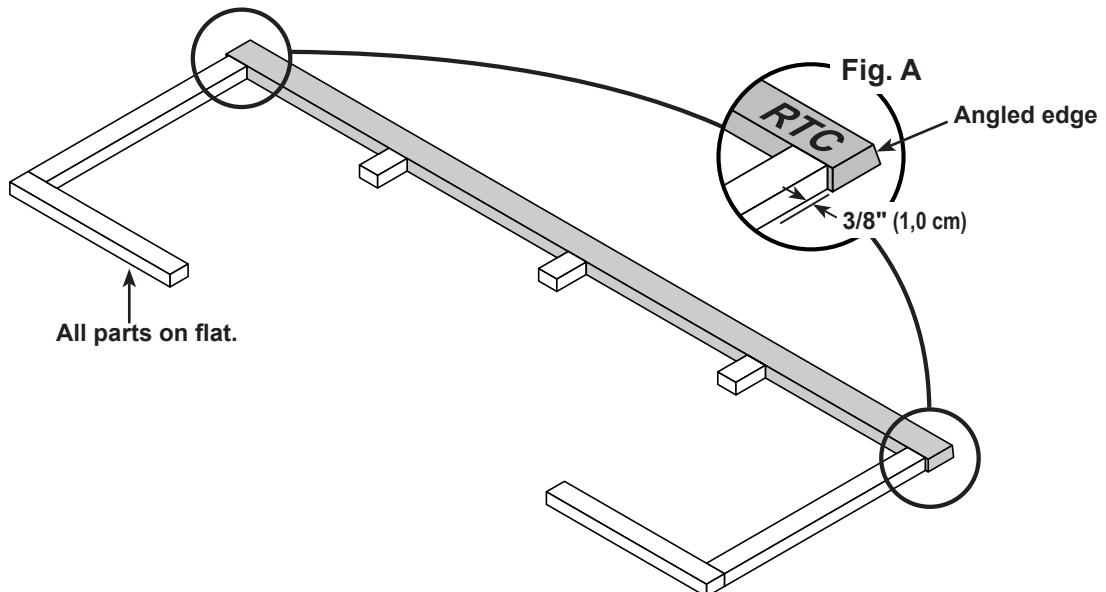

# FRONT WALL FRAME PREASSEMBLY

## PARTS REQUIRED:

x1 **TCA**  
2 x 4 x 51" (5,1 x 10,2 x 129,5 cm)

x2 **SHR**  
2 x 4 x 70-3/8" (5,1 x 10,2 x 178,8 cm)

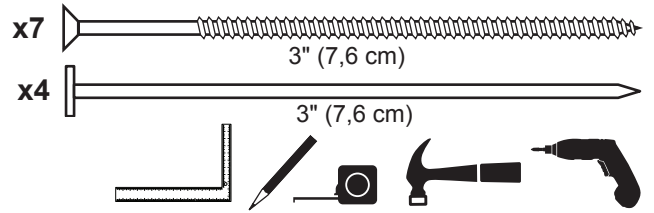

**2**

Arrange **TCA** and **SHR** on edge on floor.  
Secure parts with (2) 3" nails at each connection.

*This is the preassembled door frame.*

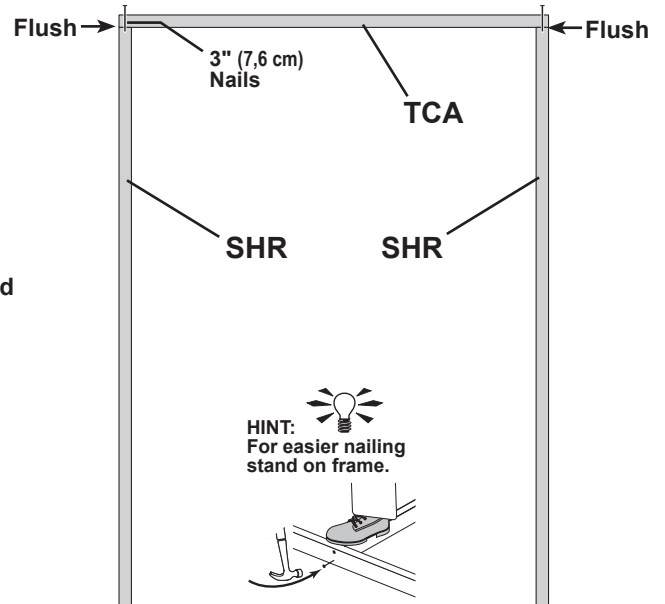
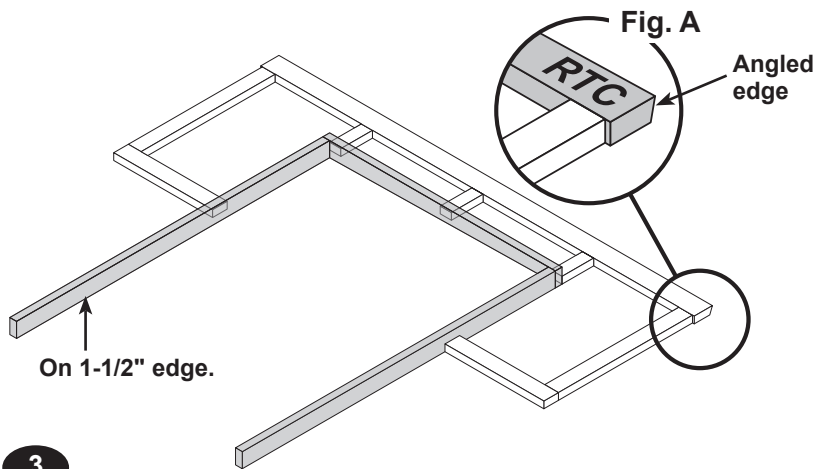

**3**

Verify that the profile angle of **TPC** is correct (**Fig. A**).

Secure door frame to upper wall assembly with 3" screws at each connection shown.

**Pre-drill all holes for 3" screws with 1/8" bit.**

**Ensure the 35-1/2" measurement to AO.**

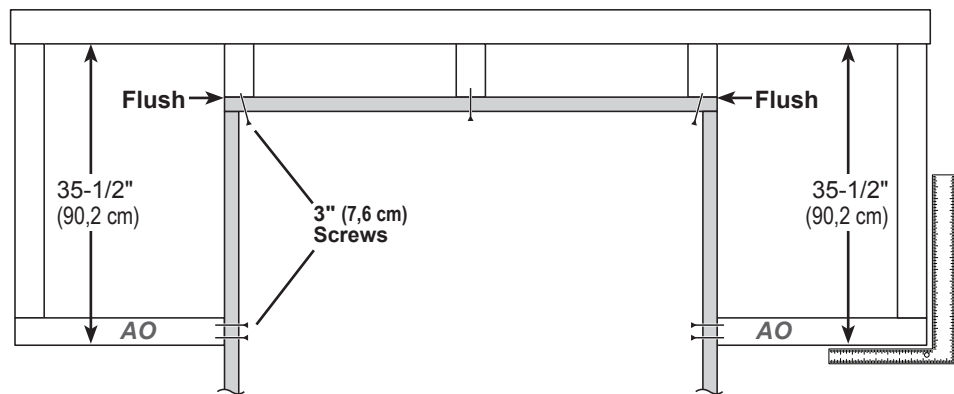

**4**

Carefully turn the preassembled door frame over,  
(reference **RTC** angle in **Fig. B**).

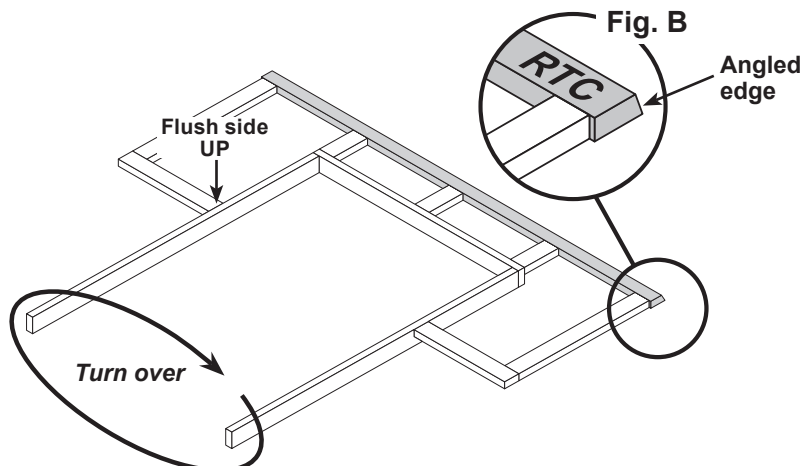

Your front wall frame is now assembled.

# FRONT WALL PANELS

## PARTS REQUIRED:

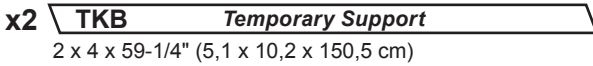
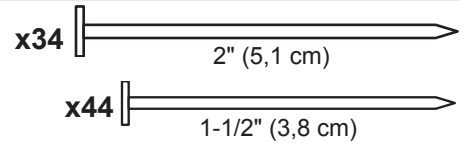
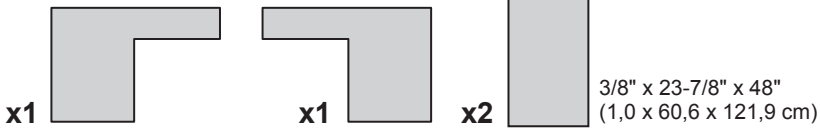

**Install wall panels with the primed side facing out.**

### ✓ BEGIN

**1**

Place (2) upper wall panels over frame. Flush panels in center and sides, as shown.

**Note the 1-3/4" measurement at bottom of panels.**

**HINT:** Support frame when nailing using (2) TKB as temporary supports.

Secure panels with 2" nails into door frame only. Secure all other parts with 1-1/2" nails.

Space nails 6" apart along edges.

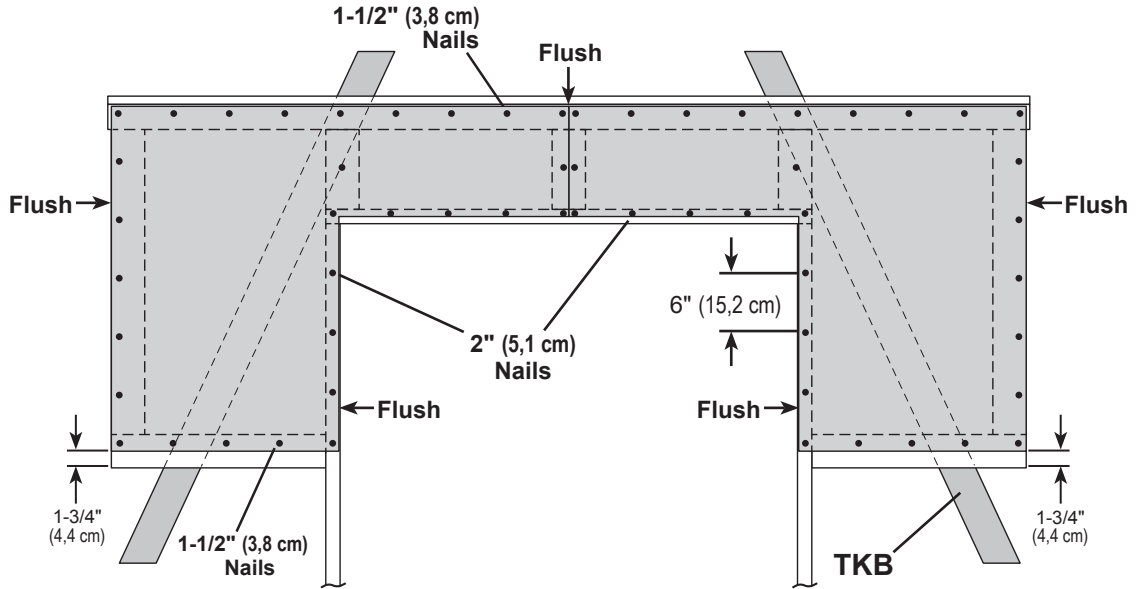

**2**

Install (2) lower wall panels flush to installed panels and flush to the door frame.

**Maintain the 48" measurement in the door opening.**

Secure panels with 2" nails into door frame only. Secure all other parts with 1-1/2" nails.

Space nails 6" apart along edges.

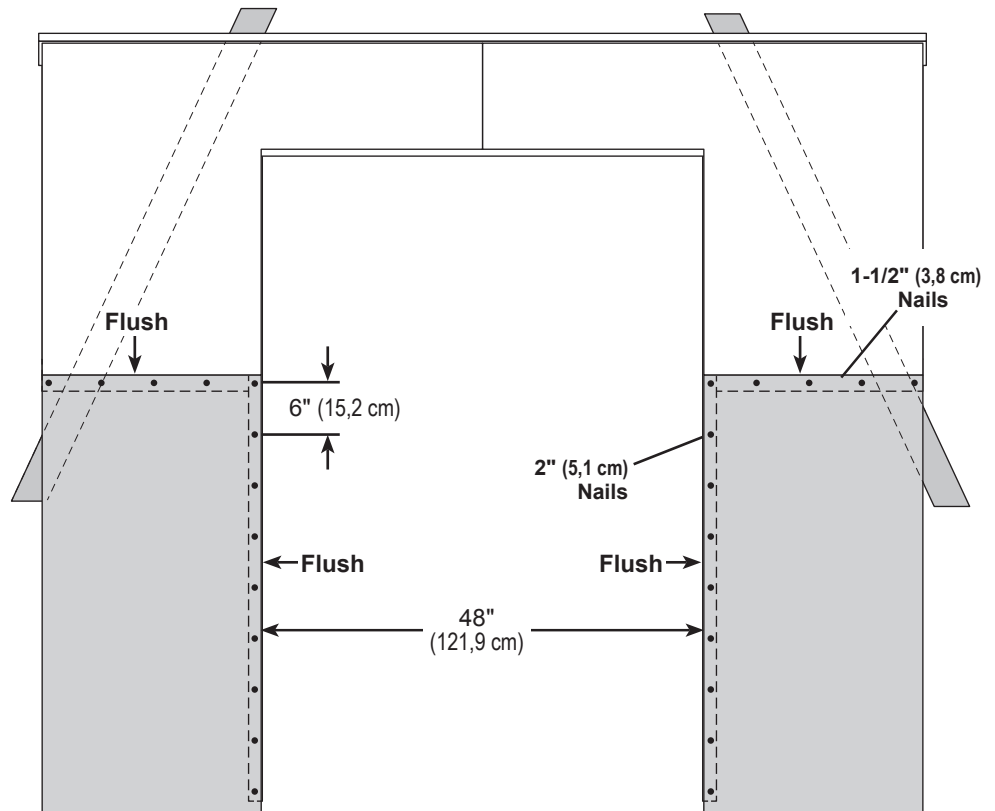

Your front wall is now assembled.

# MIDDLE AND UPPER SIDE WALL

## PARTS REQUIRED:

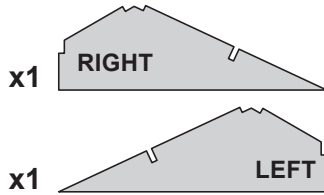
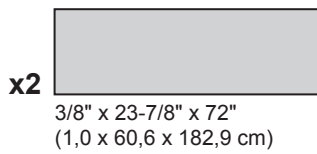

- x2 **UNB**  
 2 x 4 x 25-1/2" (5,1 x 10,2 x 64,8 cm)
- x2 **TKB**  
 2 x 4 x 59-1/4" (5,1 x 10,2 x 150,5 cm)
- x2 **RTJ**  
 2 x 4 x 70-1/2" (5,1 x 10,2 x 179,1 cm)

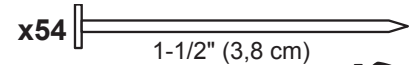

**Build 1 left and 1 right middle and upper walls.**

**BEGIN**  
**1**

Place (1) 23-7/8" x 72" middle wall panel over RTJ.  
**Ensure the primed side is facing up.**

Flush panel to angled end of RTJ, as shown.  
**Note the 1-3/4" measurement at top of panel.**

Secure panel with with 1-1/2" nails spaced 6" apart along panel edge.

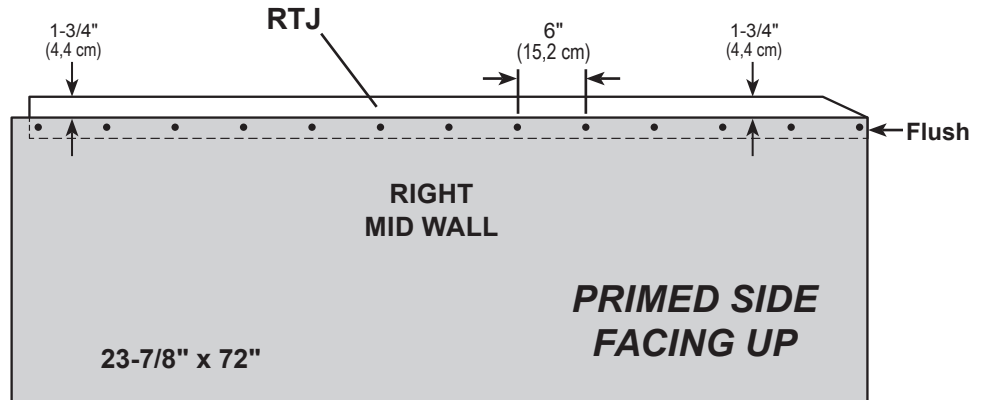

**Repeat to build the left side mid-wall (Fig. A).**



**2**

Arrange **TKB** and **UNB** on a flat surface.  
 Flush parts as shown (Fig. B).

Place right gable panel over assembled frame.  
**Ensure the primed side is facing down.**  
 Flush panel along edge of frame.

Secure panel with with 1-1/2" nails spaced 6" apart along panel edge.

**Repeat to build the left gable wall (Fig. C).**

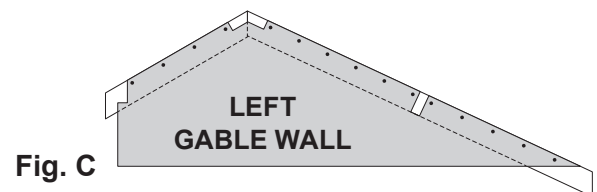
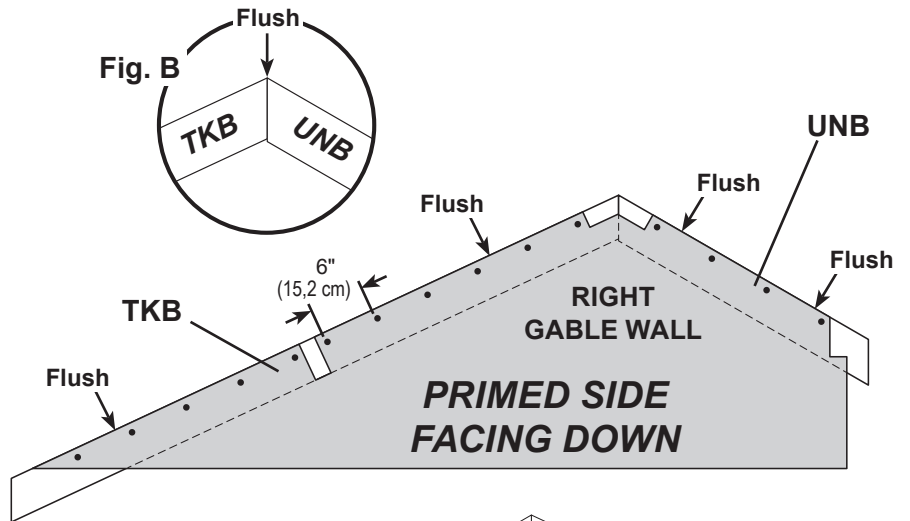

Your middle and gable side wall assemblies are now complete..

## LEFT WALL INSTALLATION

### PARTS REQUIRED

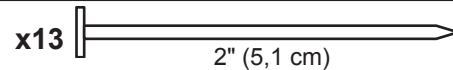
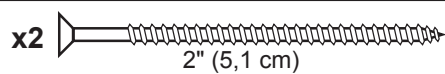

#### ✓ BEGIN 1

Center left wall on the 72" side of floor.  
Secure wall panel to floor frame with (2) 2" screws.

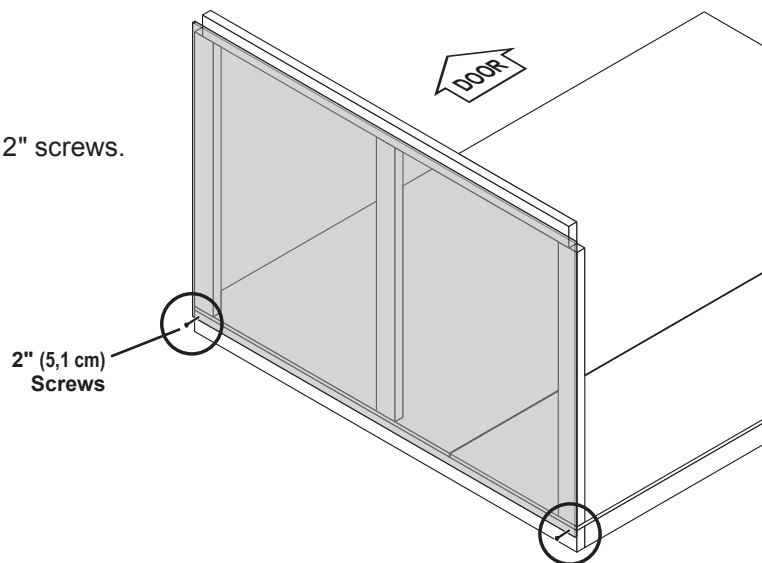

#### 2

Secure lower edge of wall panels to floor  
with 2" nails spaced 6" apart.  
**Angle nails into floor frame.**

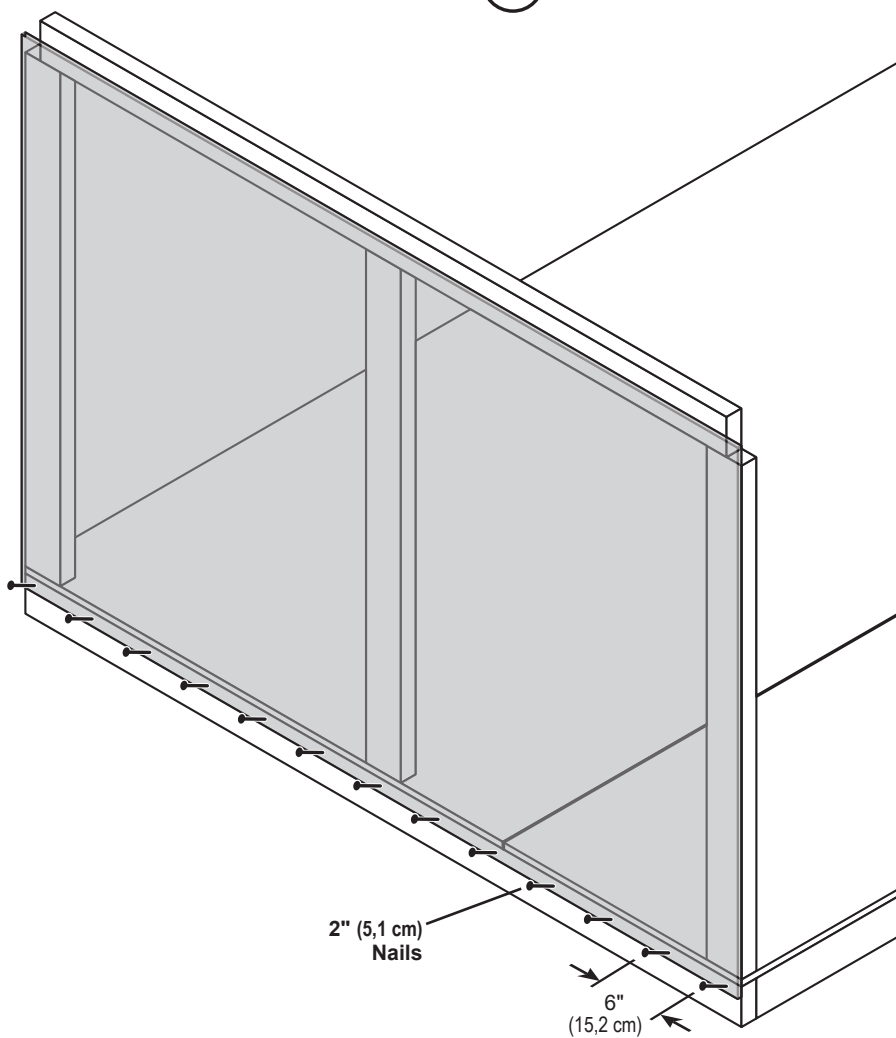

## LEFT WALL INSTALLATION

### PARTS REQUIRED

x4  3" (7,6 cm)

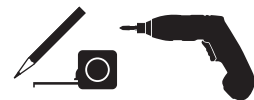

3

Secure wall studs to floor with 3" screws.

*Pre-drill holes with 1/8" bit.*

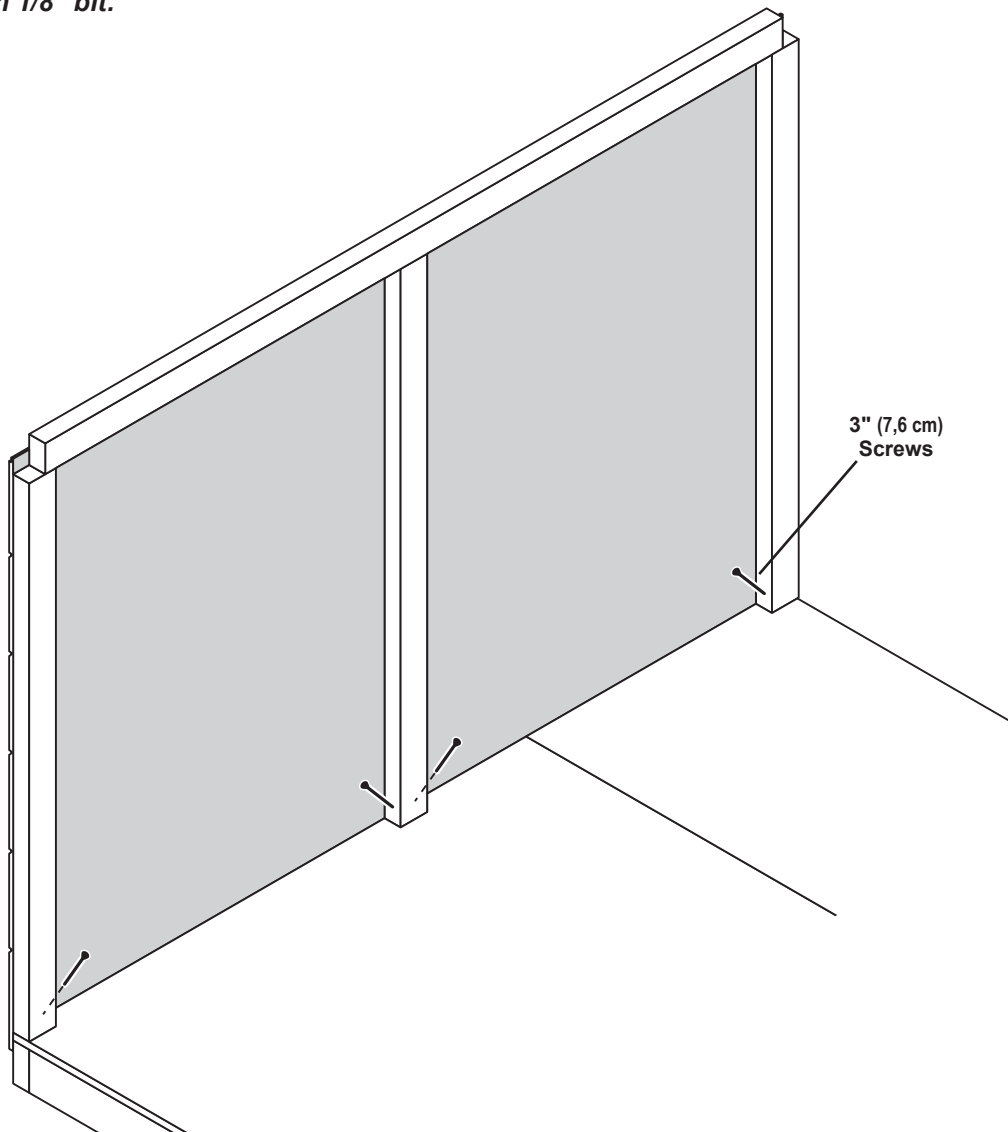

Your left wall is now installed.



# BACK WALL INSTALLATION

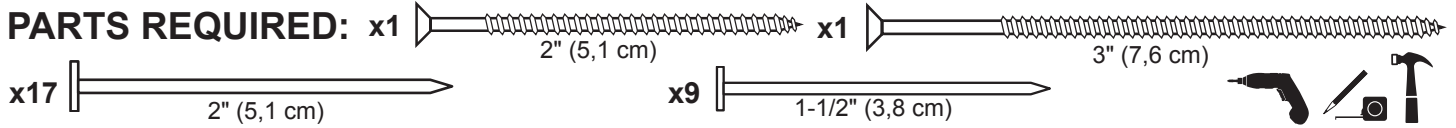

✓ **BEGIN**  
**1**

Center back wall on the floor.

At bottom of back wall, secure back wall panel to left wall stud with (1) 2" screw.

*Ensure corners are flush.*

*Pre-drill holes with 1/8" bit.*

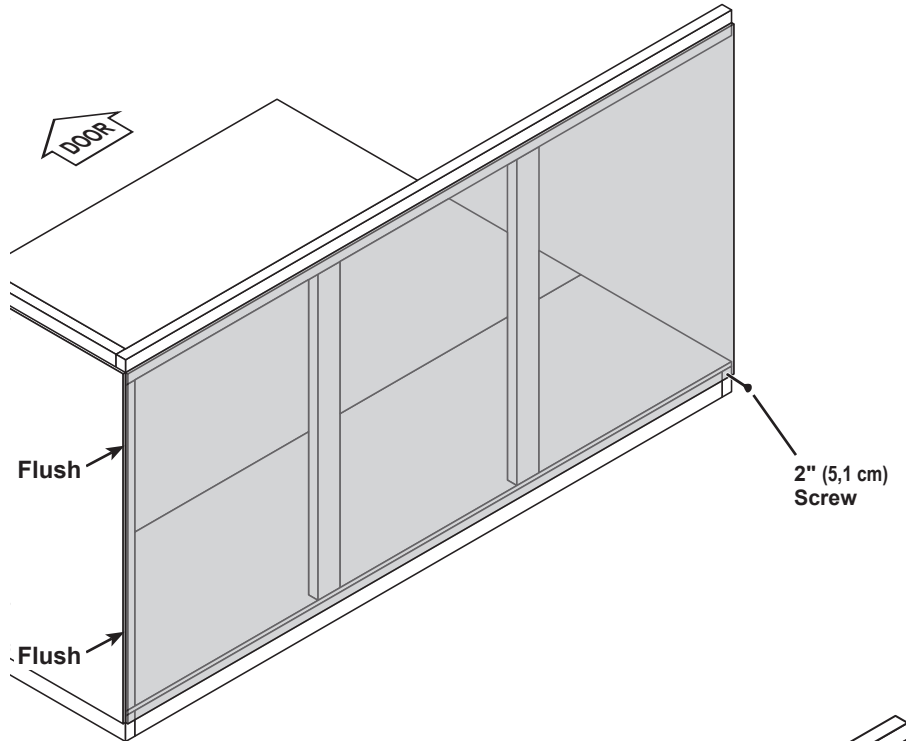

**2**

Secure lower edge of panel to floor frame with 2" nails spaced 6" apart.

*Angle nails into floor frame.*

**3**

Secure back wall panel to left wall stud with 1-1/2" nails spaced 6" apart.

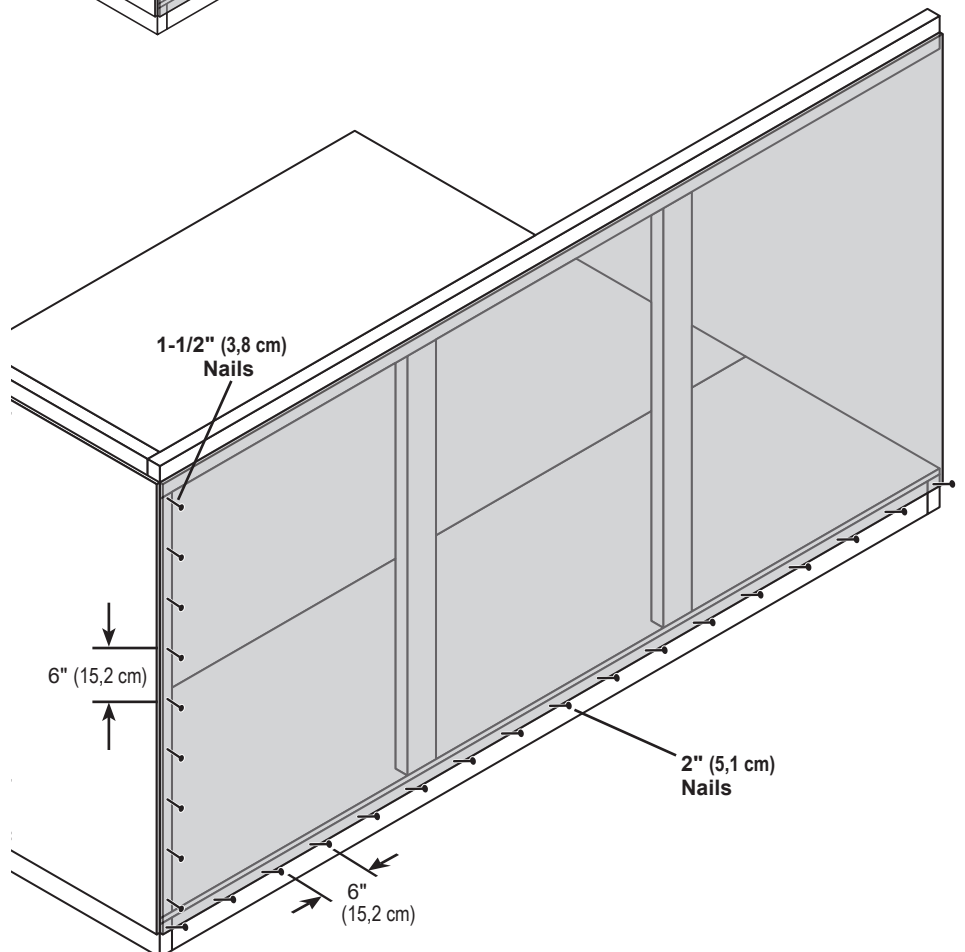

## BACK WALL INSTALLATION

### PARTS REQUIRED:

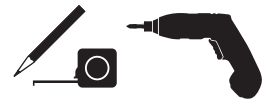
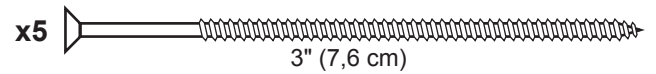

4

Working inside, secure left wall stud to back wall framing with (1) 3" screw at an angle (**Fig. A**).

Secure wall studs with 3" screws angled into floor.

*Predrill all holes with 1/8" bit.*

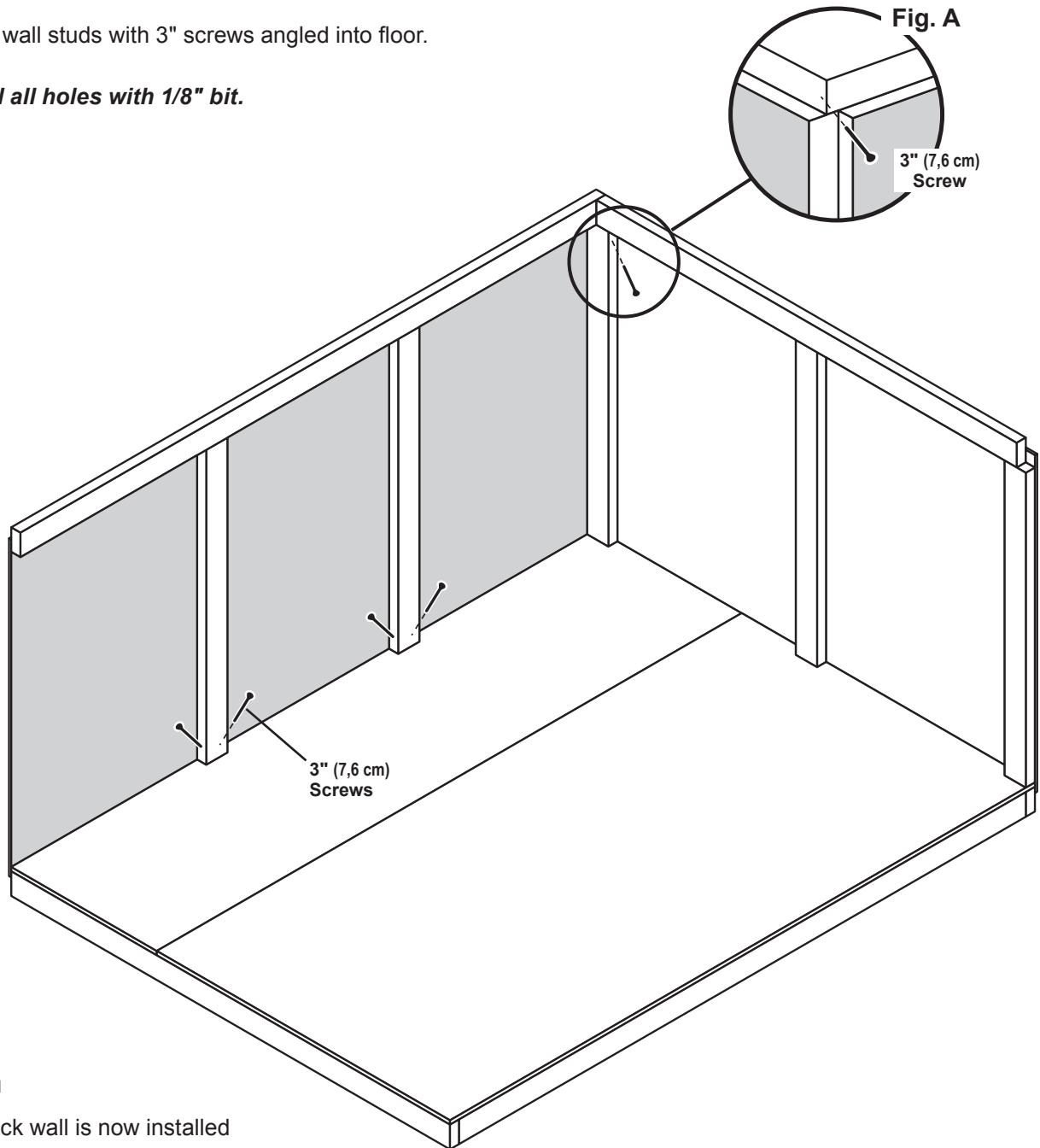

Your back wall is now installed

# RIGHT WALL INSTALLATION

## PARTS REQUIRED

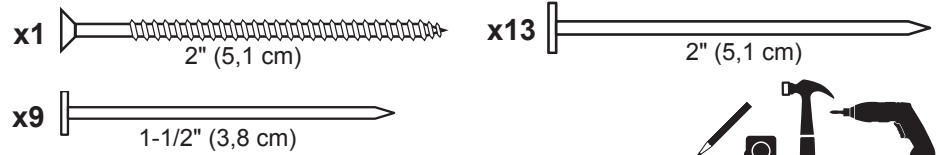

### ✓ BEGIN 1

Center right wall on the floor.

At bottom of back wall, secure back wall panel to right wall stud with (1) 2" screw.

**Ensure corners are flush.**

**Predrill hole with 1/8" bit.**

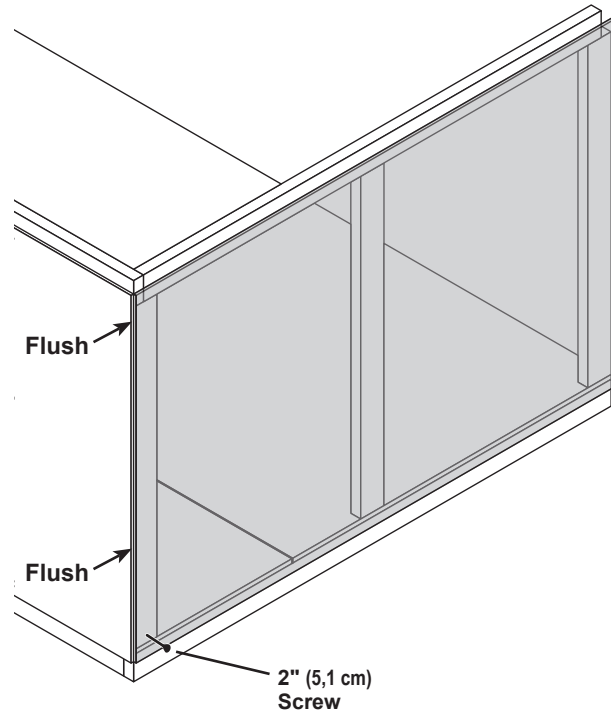

### 2

Secure lower edge of panel to floor frame with 2" nails spaced 6" apart.

**Angle nails into floor frame.**

### 3

Secure back wall panel to right wall stud with 1-1/2" nails spaced 6" apart.

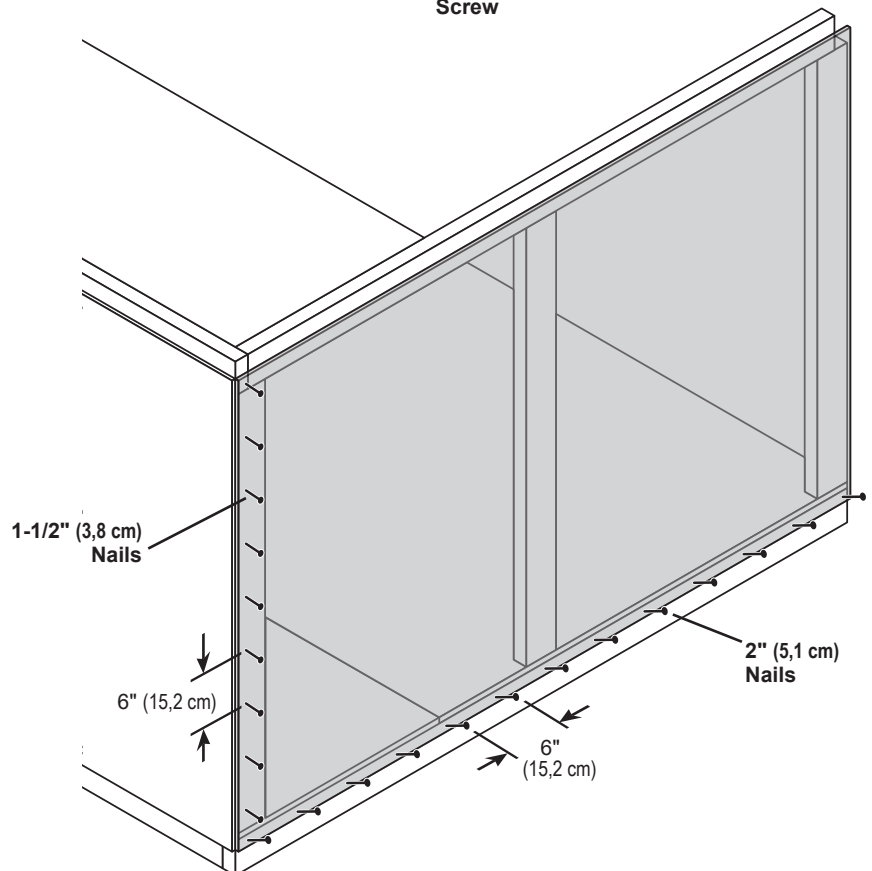

## RIGHT WALL INSTALLATION

### PARTS REQUIRED

x5  3" (7,6 cm)

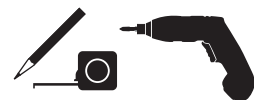

4

Working inside, secure right wall stud to back wall framing with (1) 3" screw at an angle (**Fig. A**).

Secure wall studs with 3" screws angled into floor.

*Predrill all holes with 1/8" bit.*

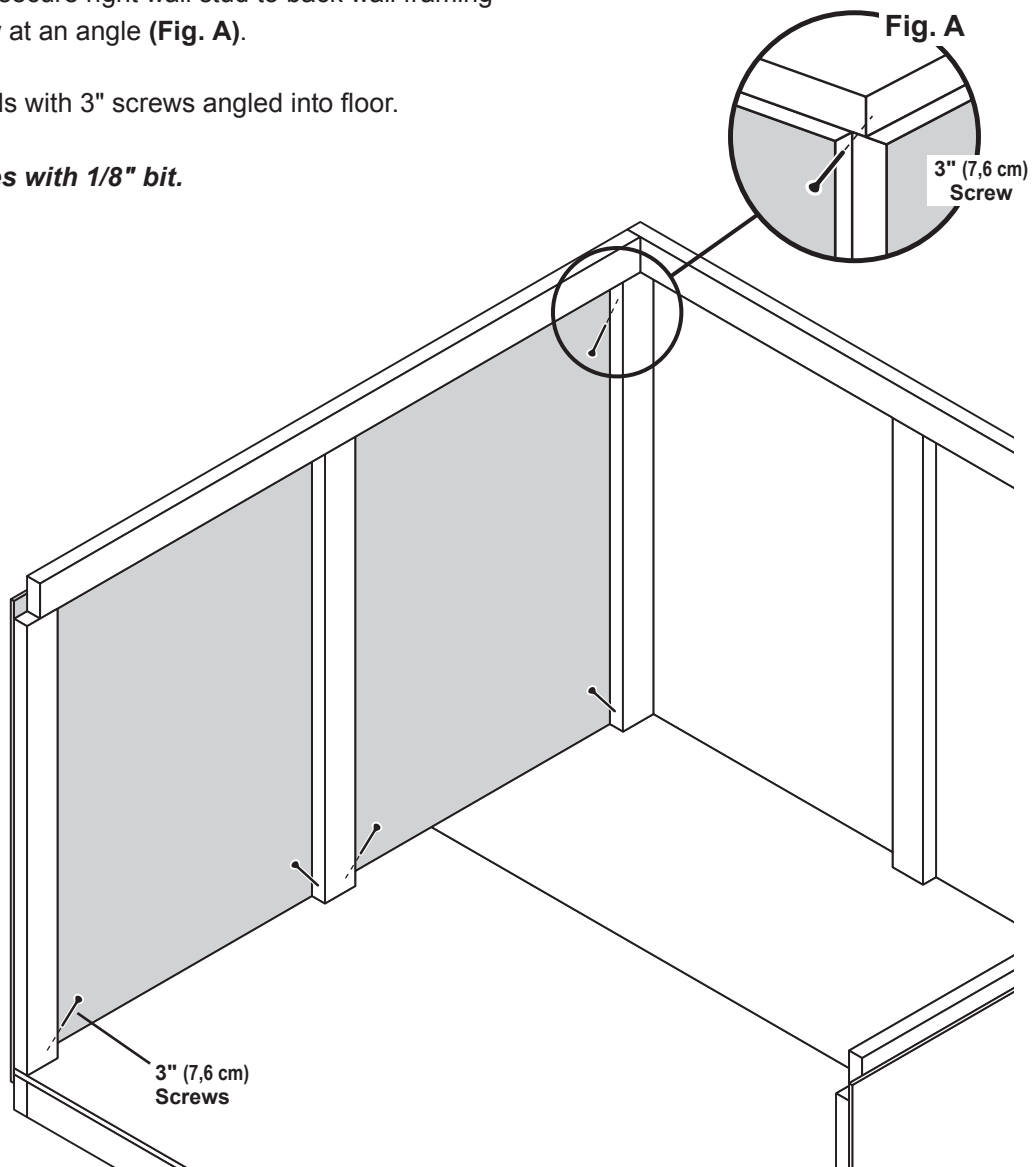

Your right wall is now installed.

# FRONT WALL INSTALLATION

## PARTS REQUIRED

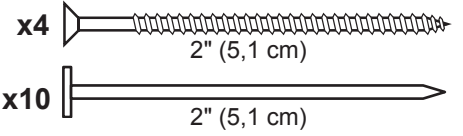

### ✓ BEGIN 1

Center front wall on the floor.

Secure bottom of front wall panels to side wall studs with (2) 2" screws.

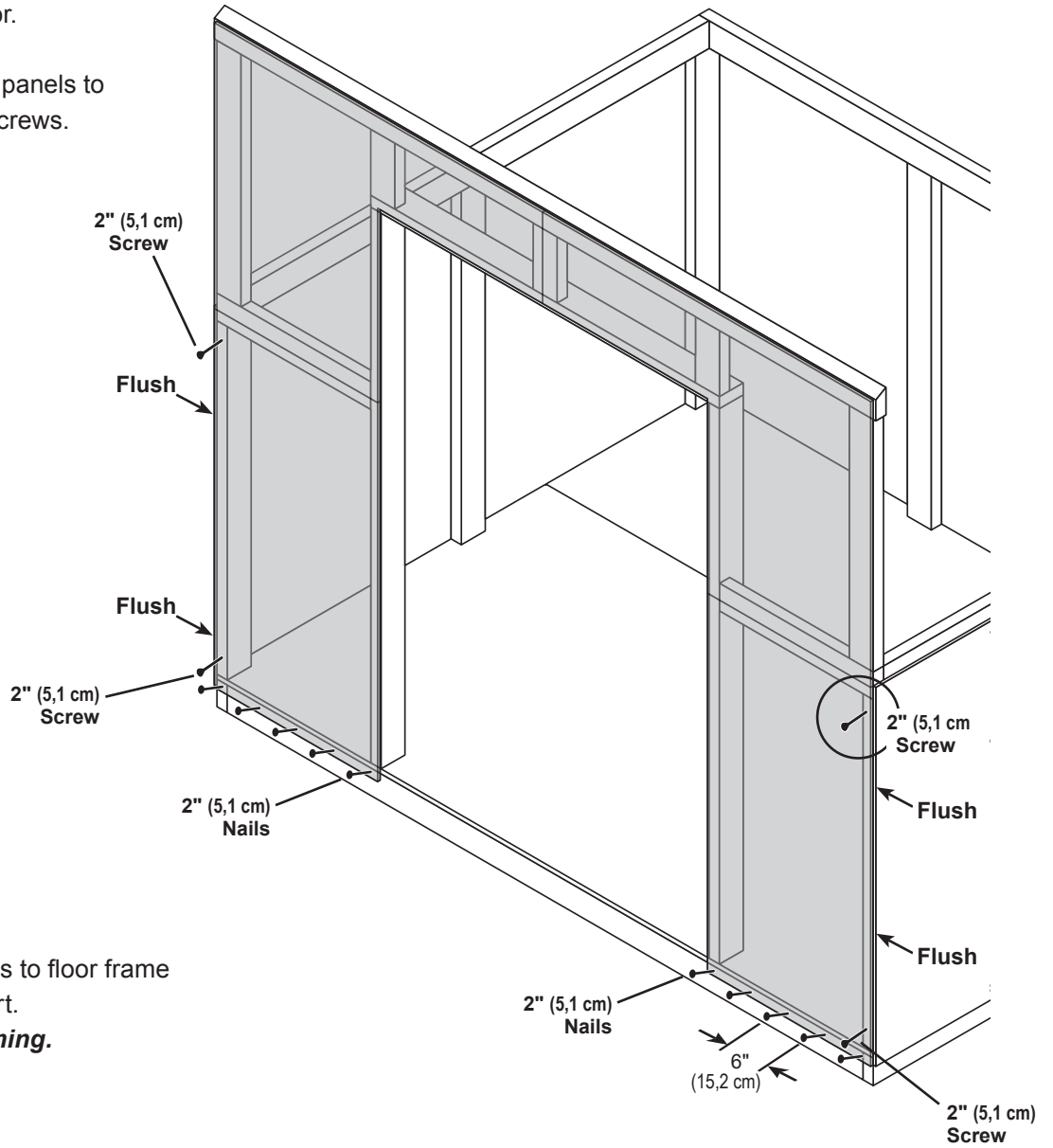

### 2

Secure lower edge of panels to floor frame with 2" nails spaced 6" apart.

**Angle nails into floor framing.**

## FRONT WALL INSTALLATION

### PARTS REQUIRED

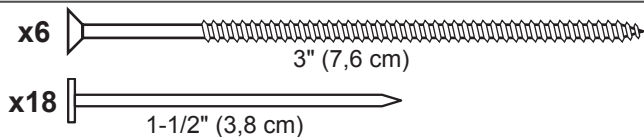

3

Secure front wall panels to side wall studs with 1-1/2" nails spaced 6" apart.

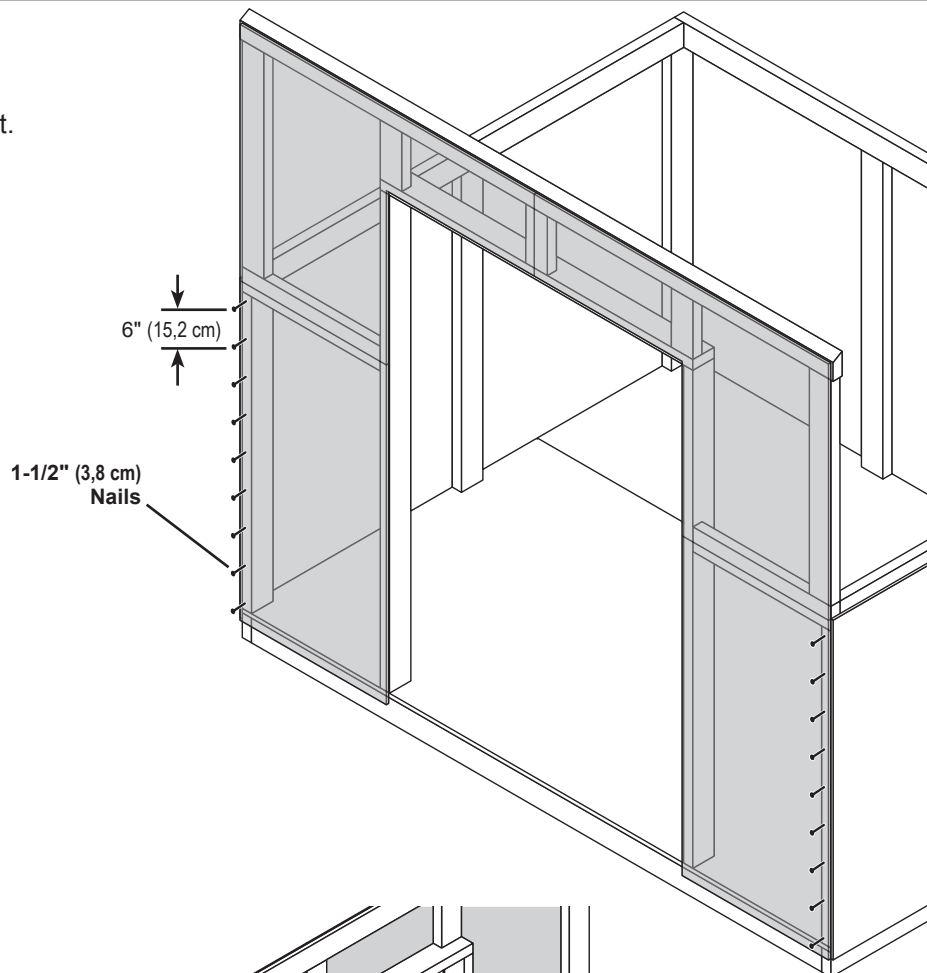

4

Working inside, secure side wall studs to front wall framing with (1) 3" screw at an angle (Fig. B).

**Pre-drill all holes with 1/8" bit.**

Secure wall studs with 3" screws angled into floor.

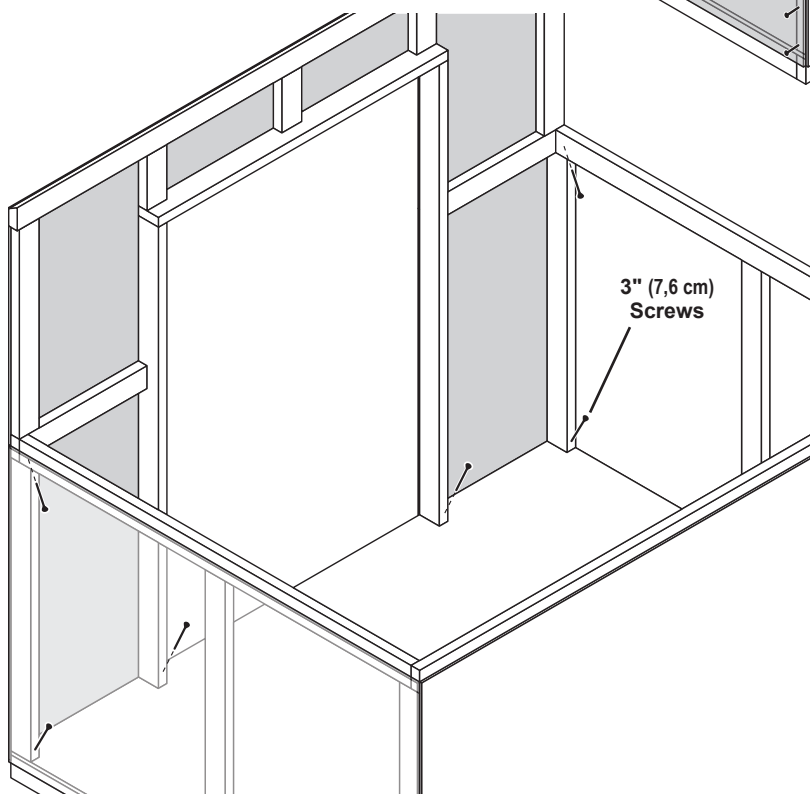

Your front wall is now installed.

## UPPER BACK WALL INSTALLATION

### PARTS REQUIRED:

x1  Pre-assembled

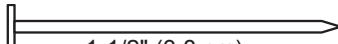

x17  1-1/2" (3,8 cm)

✓ **BEGIN**  
**1**

Center pre-assembled upper back wall on the lower back wall.

Secure lower edge of upper back wall panel to lower back wall frame with 1-1/2" nails spaced 6" apart.

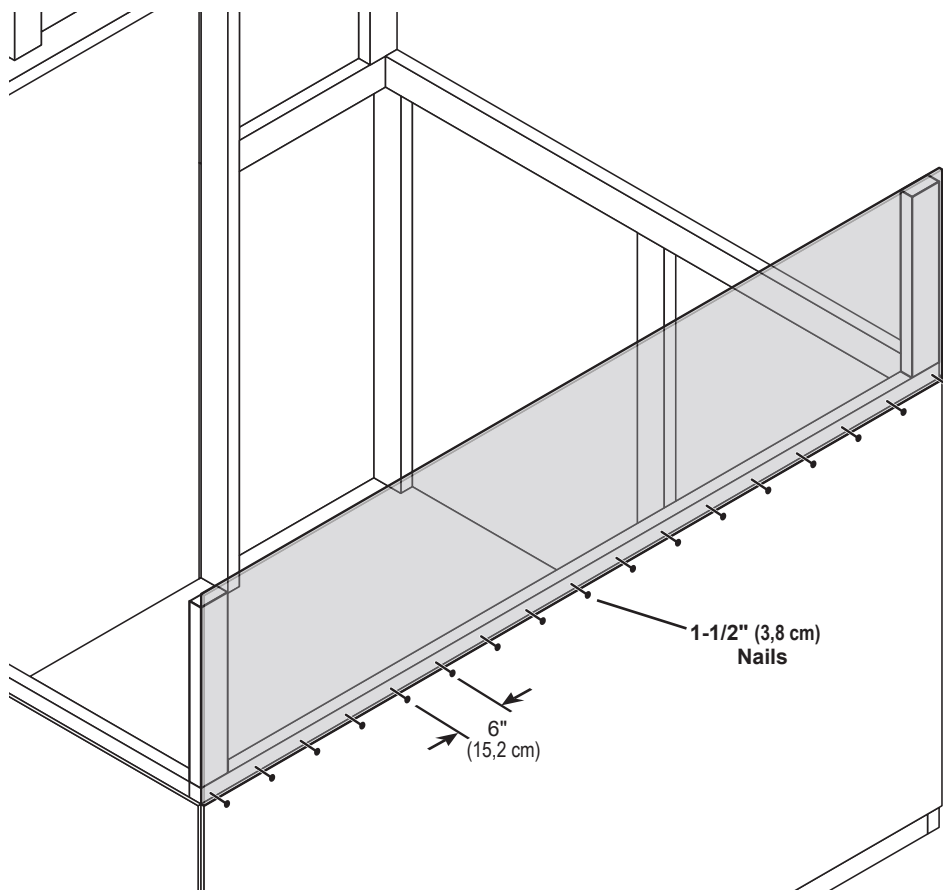

 **FINISH**

Your back wall is now complete.



will these be used? x6

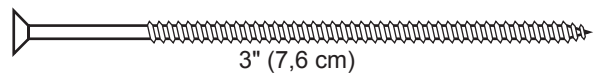

# MIDDLE SIDE WALLS

## PARTS REQUIRED:

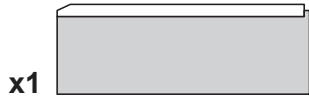
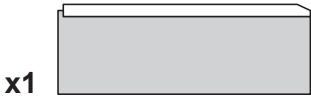

x1

x1

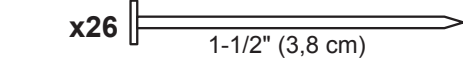
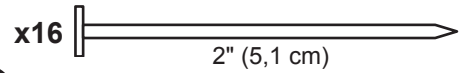
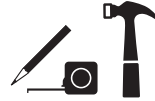

**BEGIN**  
**1**

Install (2) middle side walls flush along front and back wall corner panels.

Secure panel to vertical framing with 2" nails spaced 6" apart.

Secure panel to lower wall framing with 1-1/2" nails spaced 6" apart.

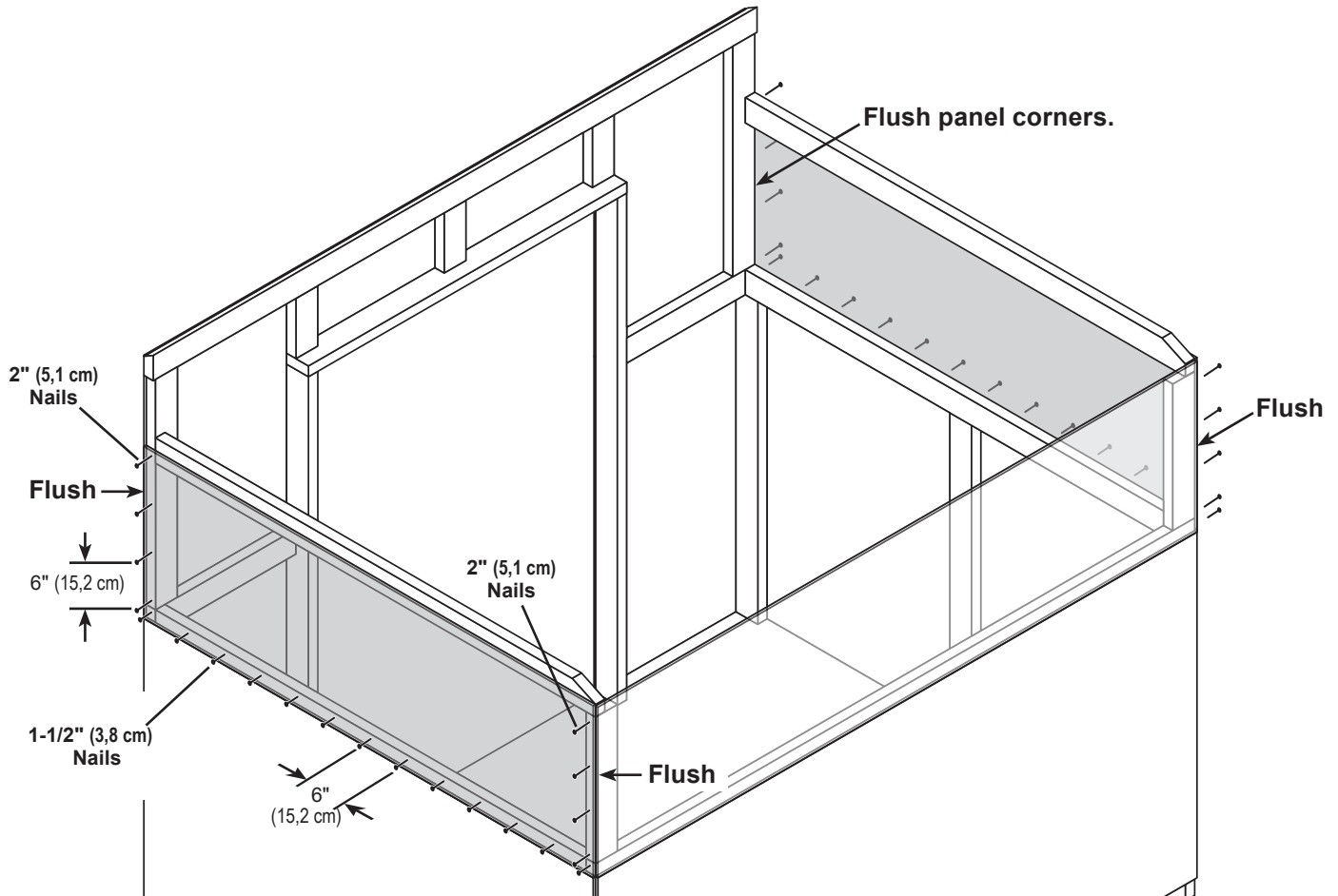

Your middle side walls are now installed.





will these be used? x6

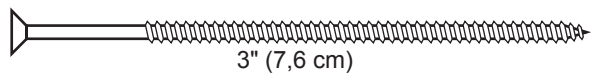

## SIDE WALL GABLE UNITS

### PARTS REQUIRED:

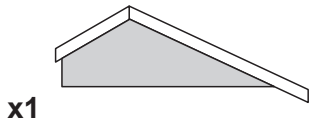

x1

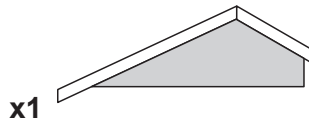

x1

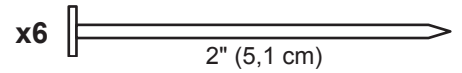

x6

2" (5,1 cm)

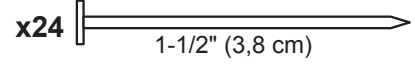

x24

1-1/2" (3,8 cm)

✓ **BEGIN**  
**1**

Install (2) gable units flush along front and back wall corner panels.

Secure panel to vertical framing with 2" nails evenly spaced.

Secure panel to side wall framing with 1-1/2" nails spaced 6" apart.

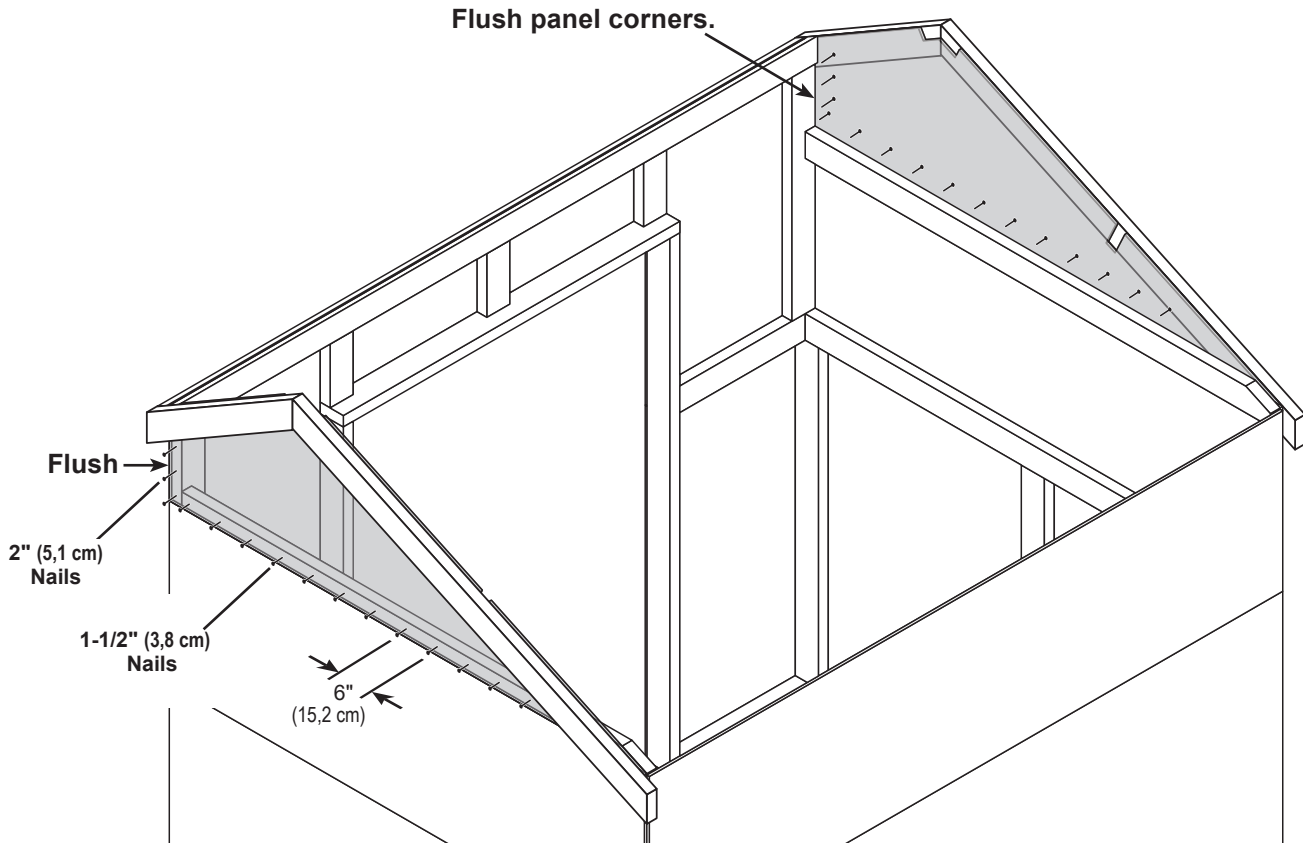

Your gable units are now installed.

## ROOF OVERHANG - BACK

### PARTS REQUIRED:

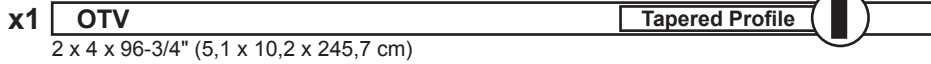
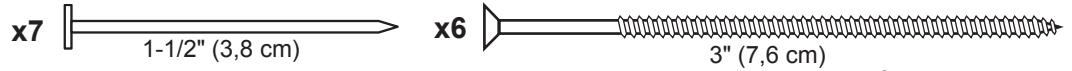

### ✓ BEGIN

1

Install angled purlin **OTV** flush to side wall trim and flush along upper back panel edge. Ensure angled profile is correct.

Secure **OTV** to vertical framing with (2) 3" screws.

Secure side trim to **OTV** with (2) 3" screws at each side.

*Predrill holes with 1/8" bit.*

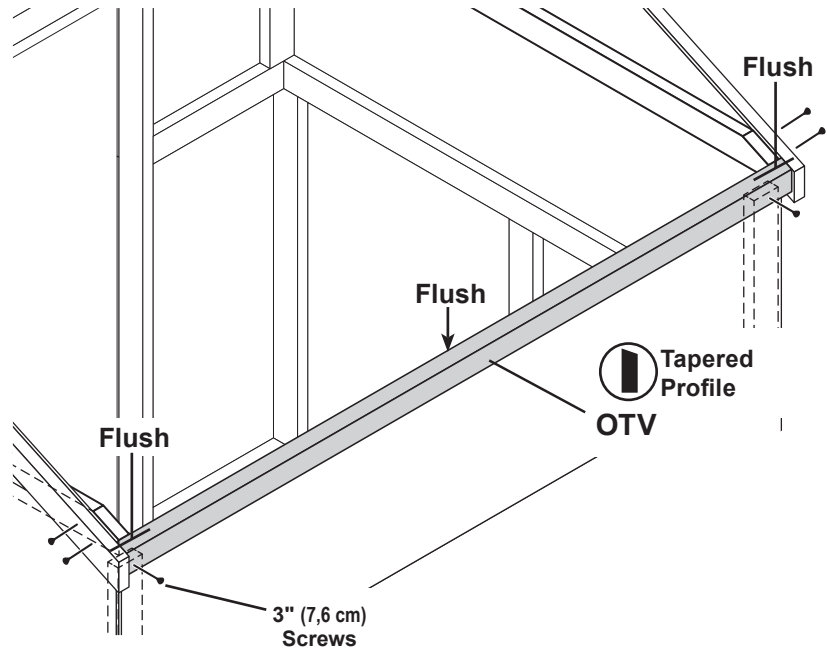

2

Working inside, secure **OTV** with 1-1/2" nails evenly spaced.

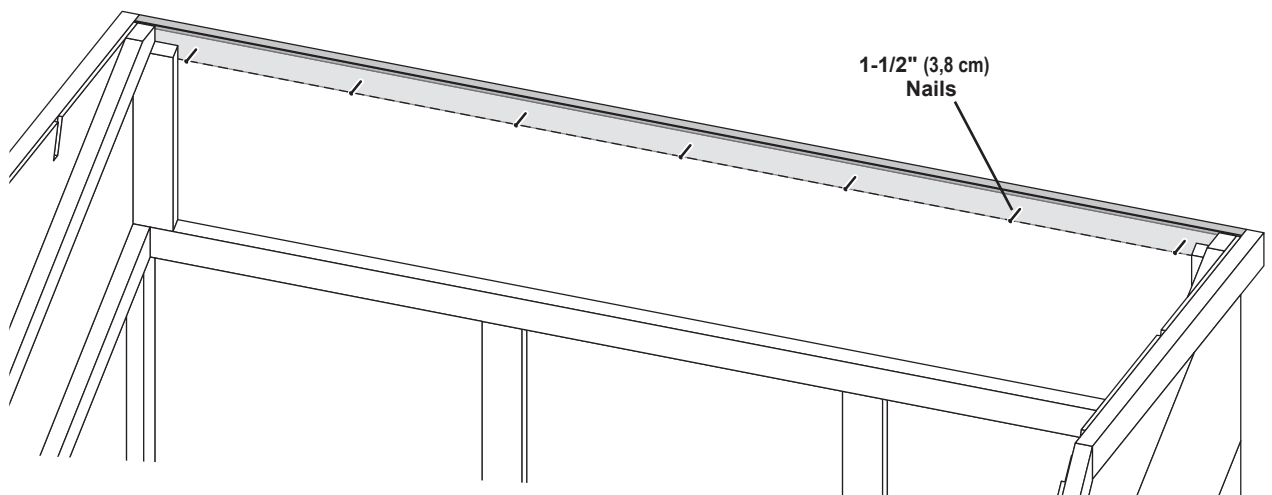

Your back overhang is now installed.

## ROOF OVERHANG - FRONT

### PARTS REQUIRED:

x10  3" (7,6 cm)

x1 **RTC**  **Tapered Profile**  *Painted black on end*  
2 x 4 x 96-3/4" (5,1 x 10,2 x 245,7 cm)

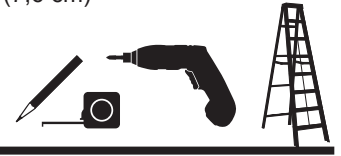

### ✓ BEGIN

1

Install angled purlin **RTC** flush to side wall trim and flush along upper front panel edge.  
Ensure angled profile is correct.

Secure side trim to **RTC** (2) 3" screws at each side.

*Predrill holes with 1/8" bit.*

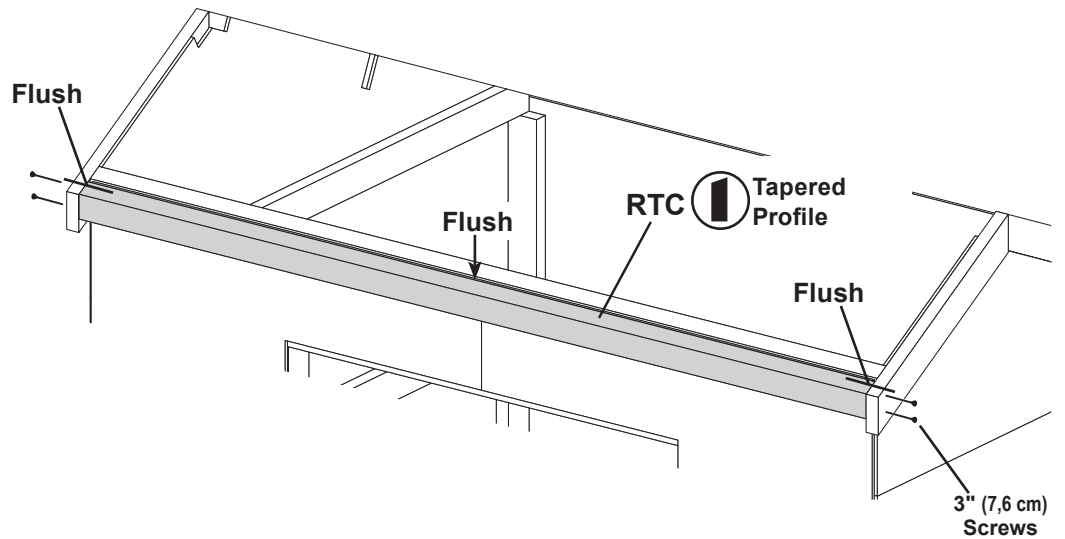

2

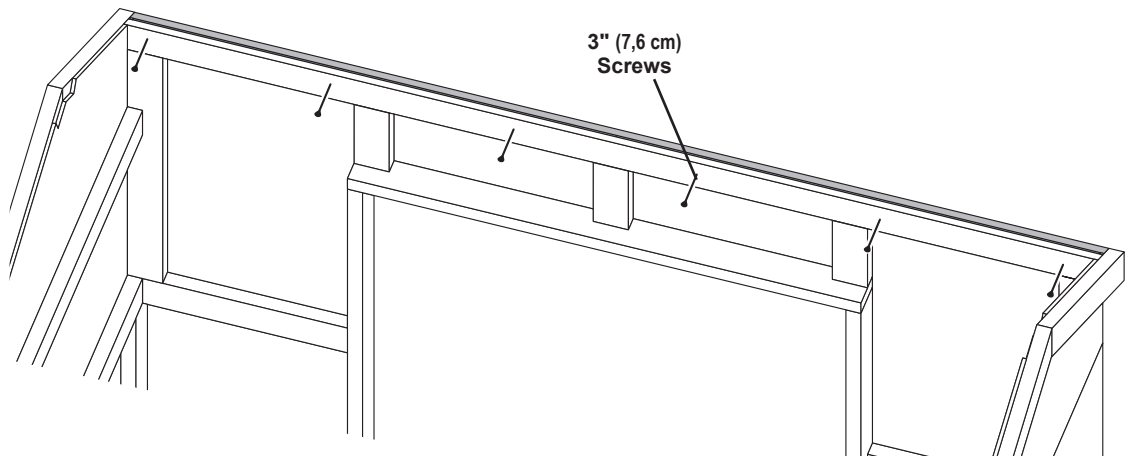

Working inside, secure **RTC** to upper front wall framing with 3" screws evenly spaced.



Your front overhang is now installed.

# ROOF PURLINS

## PARTS REQUIRED:

- x18  3" (7,6 cm)
- x1 **UXA**  
2 x 4 x 96-3/4" (5,1 x 10,2 x 245,7 cm)
- x1 **OTV**   
2 x 4 x 96-3/4" (5,1 x 10,2 x 245,7 cm)
- x1 **RTC**  Painted black on end  
2 x 4 x 96-3/4" (5,1 x 10,2 x 245,7 cm)



### BEGIN

- 1 Assemble upper roof support from tapered purlins **RTC** and **OTV**. Arrange parts as shown (**Fig. A**). Secure with (6) 3" screws, angled and evenly spaced.  
*Predrill holes with 1/8" bit.*

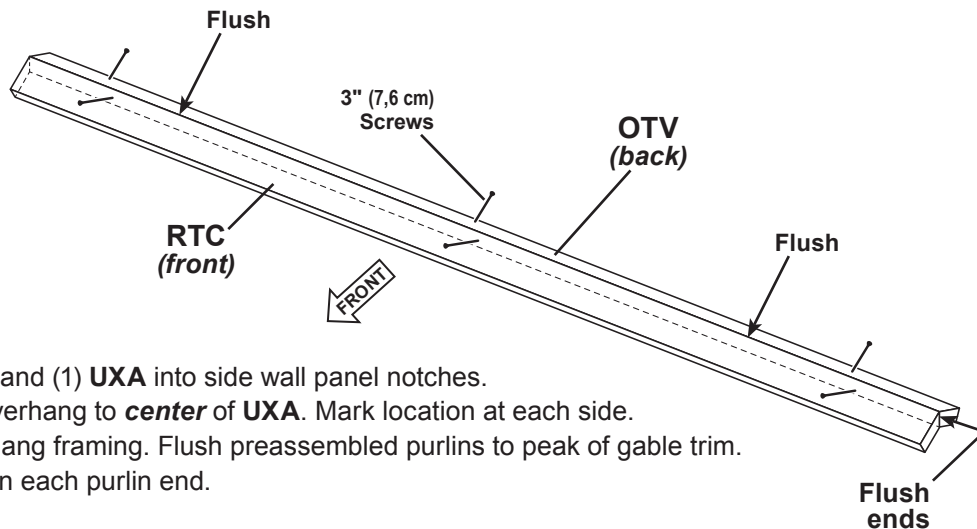
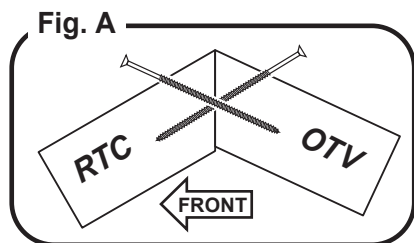

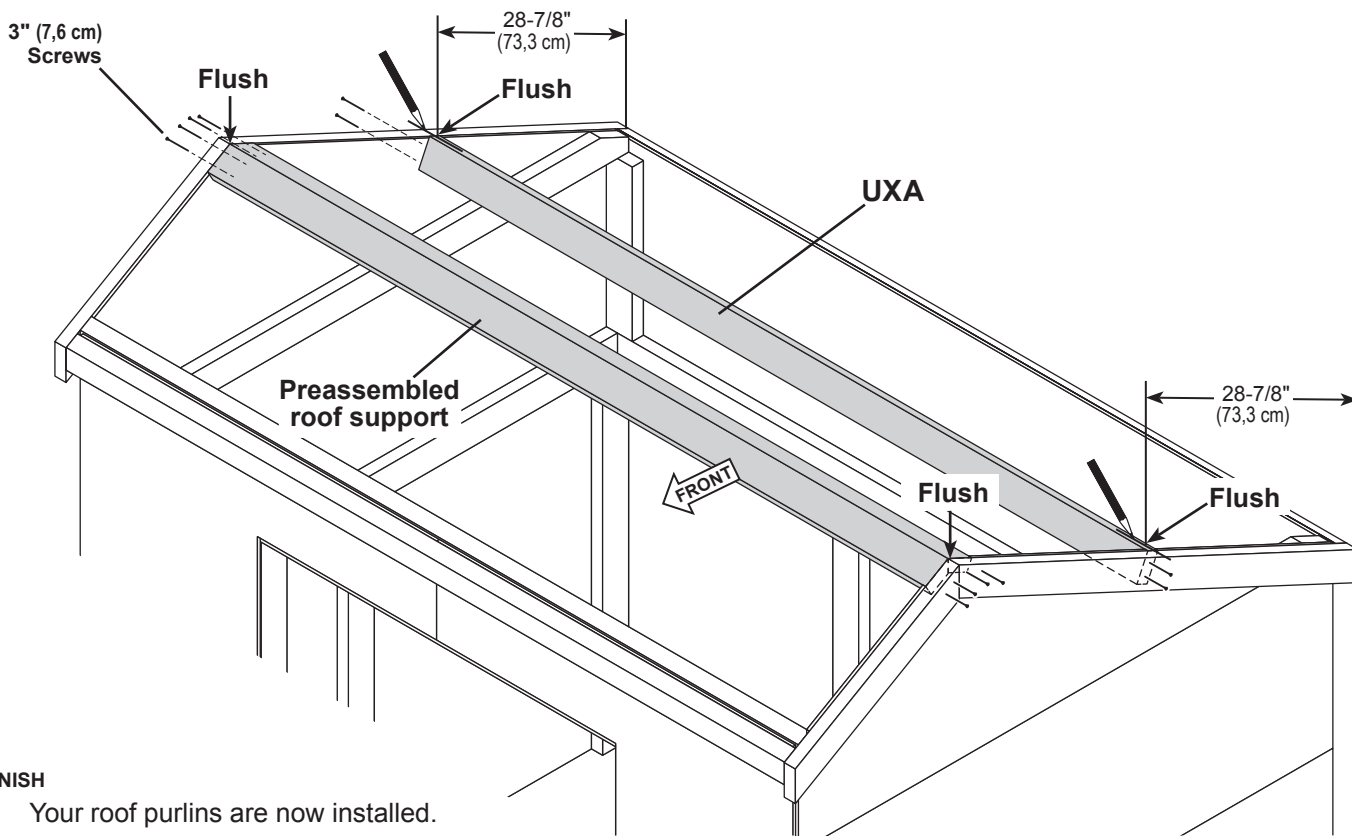

- 2 Install the preassembled purlins and (1) **UXA** into side wall panel notches. Measure from outside of back overhang to **center** of **UXA**. Mark location at each side. Flush purlins to top of side overhang framing. Flush preassembled purlins to peak of gable trim. Secure parts with (2) 3" screws in each purlin end.  
*Predrill holes with 1/8" bit.*



**FINISH**  
Your roof purlins are now installed.

# SOFFIT TRIM

## PARTS REQUIRED:

- x2  3/8" x 1-1/2" x 48-3/8" (1,0 x 12,4 x 122,9 cm)
- x2  3/8" x 1-1/2" x 25-1/4" (1,0 x 12,4 x 64,1 cm)
- x2  3/8" x 1-1/2" x 59-1/16" (1,0 x 12,4 x 150 cm)

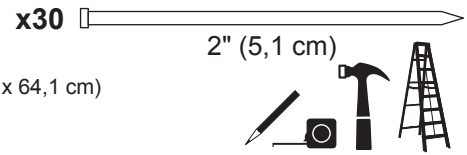

*Install soffit panels with the primed side facing down.*

### ✓ BEGIN

- 1 Install (2) 1-1/2" x 48-3/8" front soffit panels flush to 2x4 side wall gable trim. Flush trim to wall panel. Secure with 2" finishing nails evenly spaced, as shown.

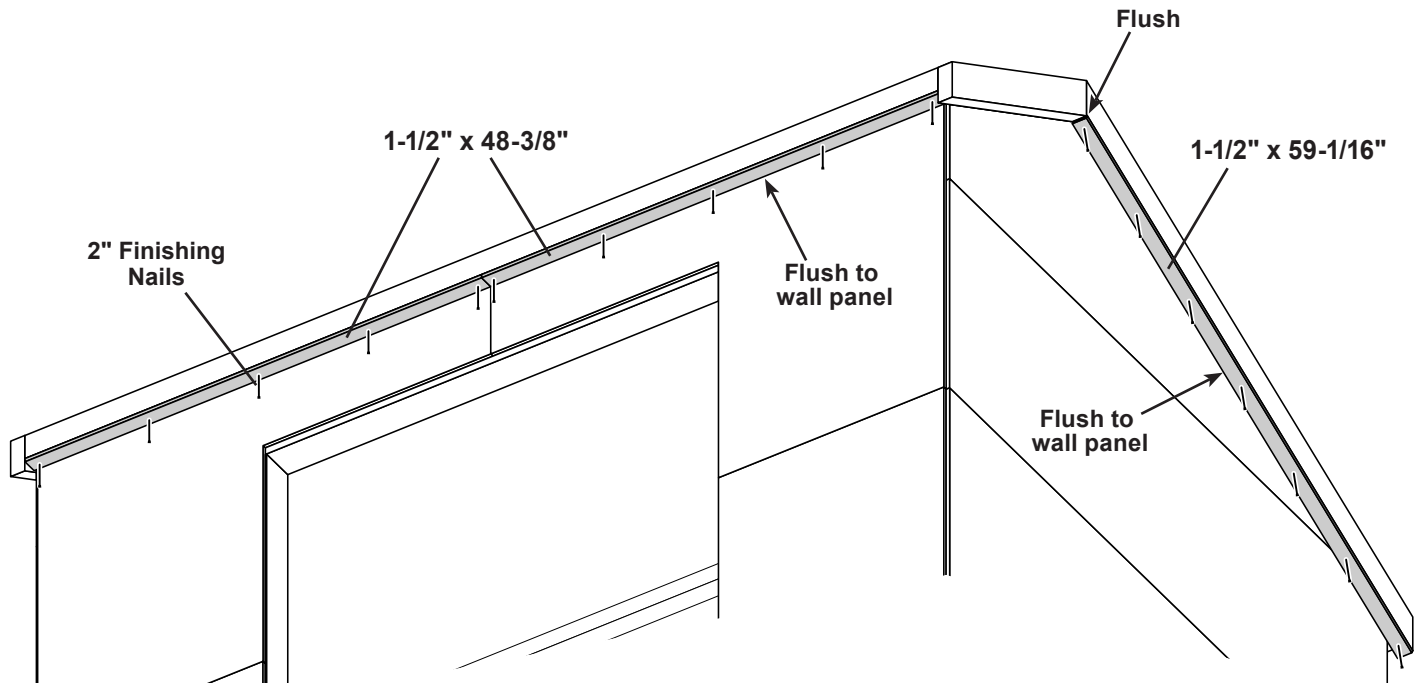

- 2 Install (2) 1-1/2" x 59-1/16" side soffit trim panel nested flush to the side trim peak. Secure with 2" finishing nails, spaced evenly.

- 3 Install (2) 1-1/2" x 25-1/4" back soffit panels flush to back wall panels and flush to installed soffit trim. Flush trim to wall panel. Secure with 2" finishing nails, as shown.

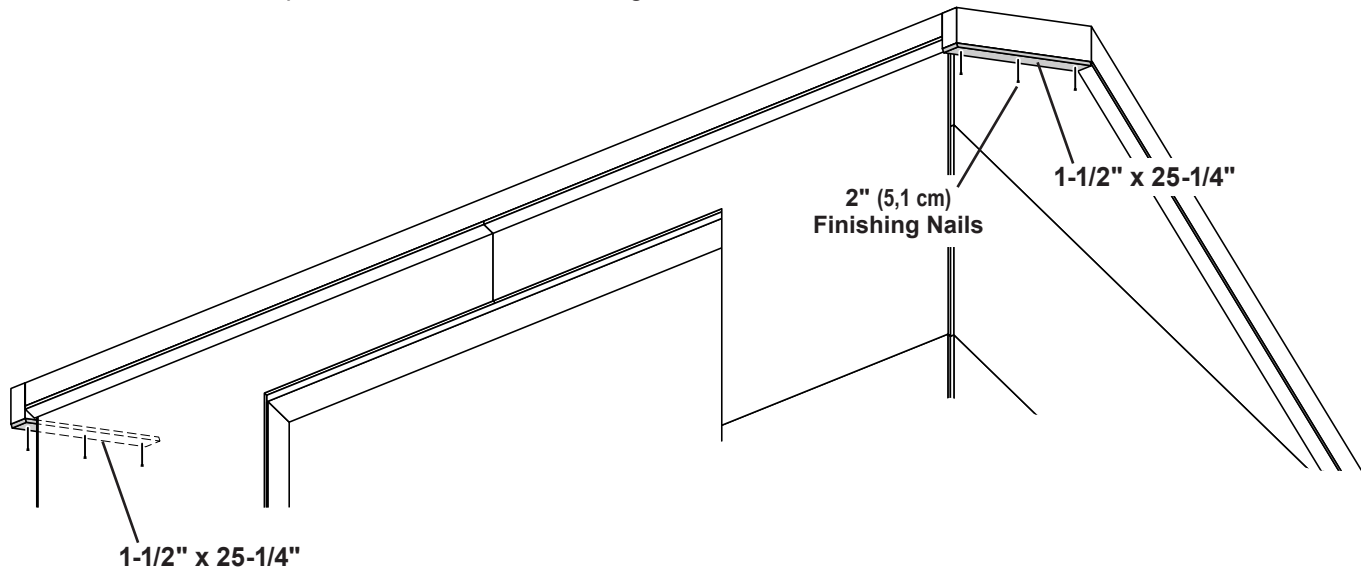

## SOFFIT TRIM

### PARTS REQUIRED:

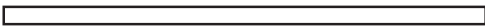
x2   
3/8" x 1-1/2" x 48-3/8" (1,0 x 12,4 x 122,9 cm)

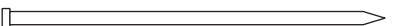
x10   
2" (5,1 cm)



*Install soffit trim with the primed side facing down.*

- 3** Install (2) 1-1/2" x 48-3/8" back soffit trim boards centered on rear overhang frame. Secure with 2" finishing nails evenly spaced, as shown.

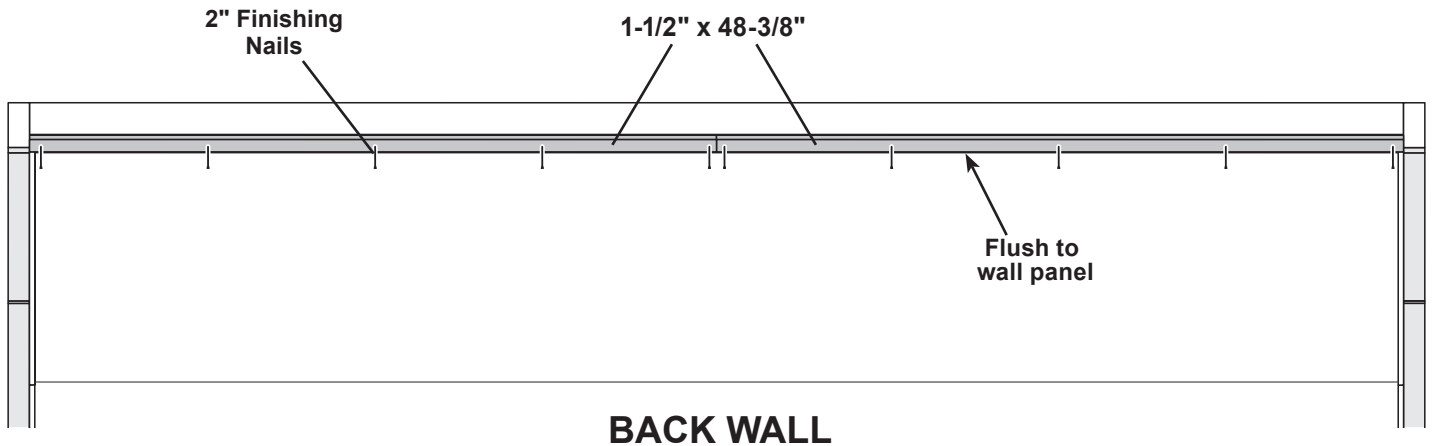

Your soffit trim panels are now installed.

# FASCIA TRIM

## PARTS REQUIRED:

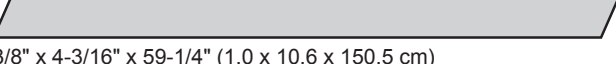
**x1**   
 3/8" x 4-3/16" x 59-1/4" (1,0 x 10,6 x 150,5 cm)

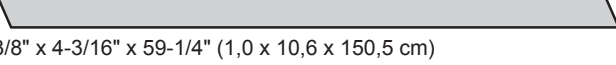
**x1**   
 3/8" x 4-3/16" x 59-1/4" (1,0 x 10,6 x 150,5 cm)

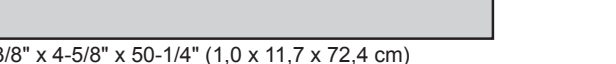
**x4**   
 3/8" x 4-5/8" x 50-1/4" (1,0 x 11,7 x 72,4 cm)

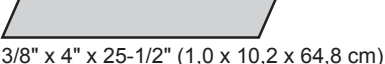
**x1**   
 3/8" x 4" x 25-1/2" (1,0 x 10,2 x 64,8 cm)

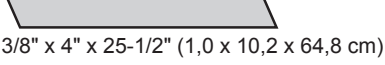
**x1**   
 3/8" x 4" x 25-1/2" (1,0 x 10,2 x 64,8 cm)

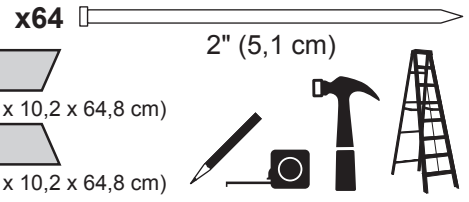

**Install trim with the primed side facing out.**

### ✓ BEGIN

- 1 Install right side 4" x 25-1/2" and 4-3/16" x 59-1/4" fascia board flush to front edge of overhang frame and flush to top of wall panels. Secure with 2" finishing nails, evenly spaced.

*Repeat to install the left fascia.*

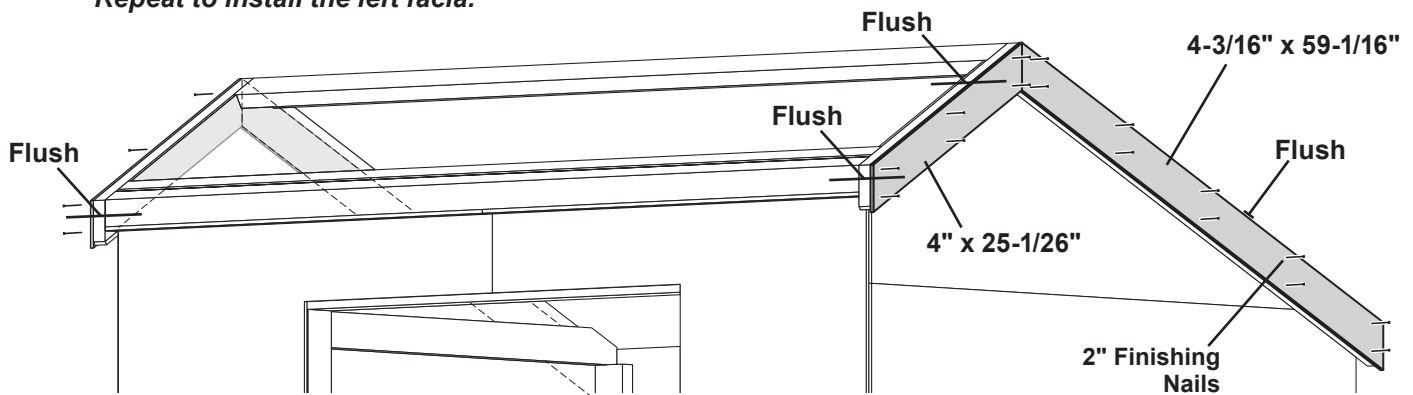

- 2 Install (2) 4-5/8" x 50-1/4" front fascia boards flush to side fascia and flush to top of front overhang framing. Secure with 2" finishing nails, spaced evenly.

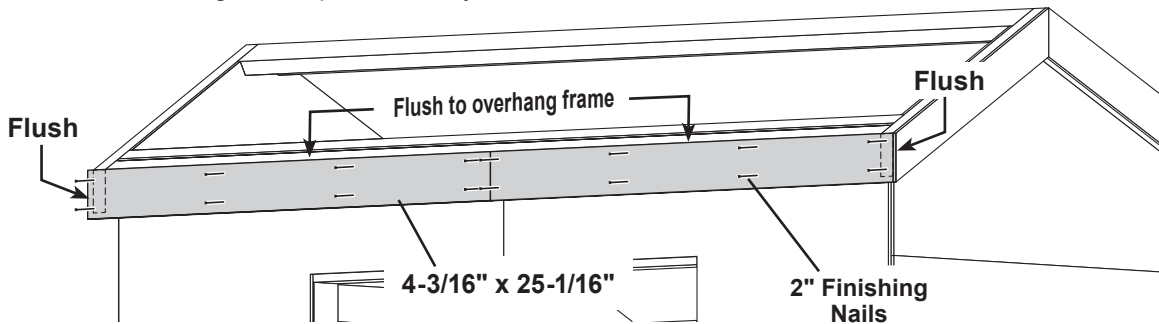

- 3 Install (2) 4-5/8" x 50-1/4" back fascia boards flush to side fascia and flush to top of front overhang framing. Secure with 2" finishing nails, spaced evenly.

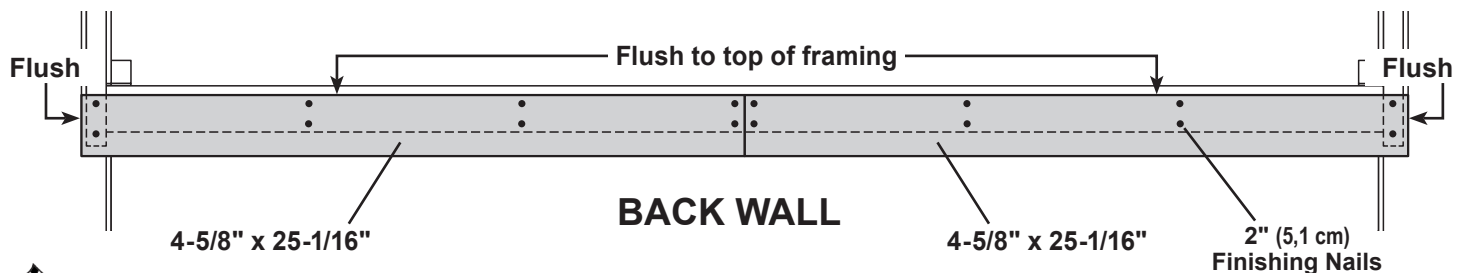

Your fascia trim boards are now installed.

# FRONT & BACK WALL TRIM

## PARTS REQUIRED:

x2   
 3/8" x 1-3/4" x 67-13/16" (1,0 x 4,4 x 172,2 cm)

x2   
 3/8" x 1-3/4" x 80-1/4" (1,0 x 4,4 x 203,8 cm)

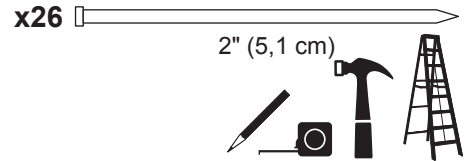

*Install trim with the primed side facing out.*

### ✓ BEGIN

1

Install (2) **80-1/4"** front corner trim flush to soffit and flush to installed corner trim.

Secure with 2" finishing nails spaced evenly.

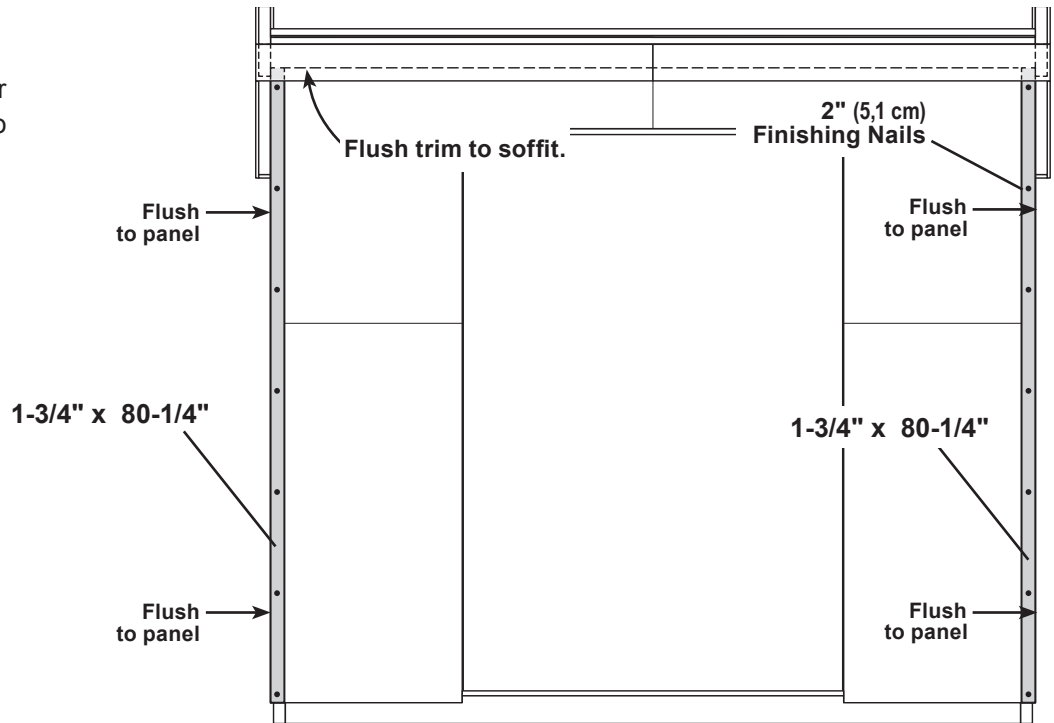

3

Install (2) **67-13/16"** back corner trim flush to soffit and flush to installed corner trim.

Secure with 2" finishing nails spaced evenly.

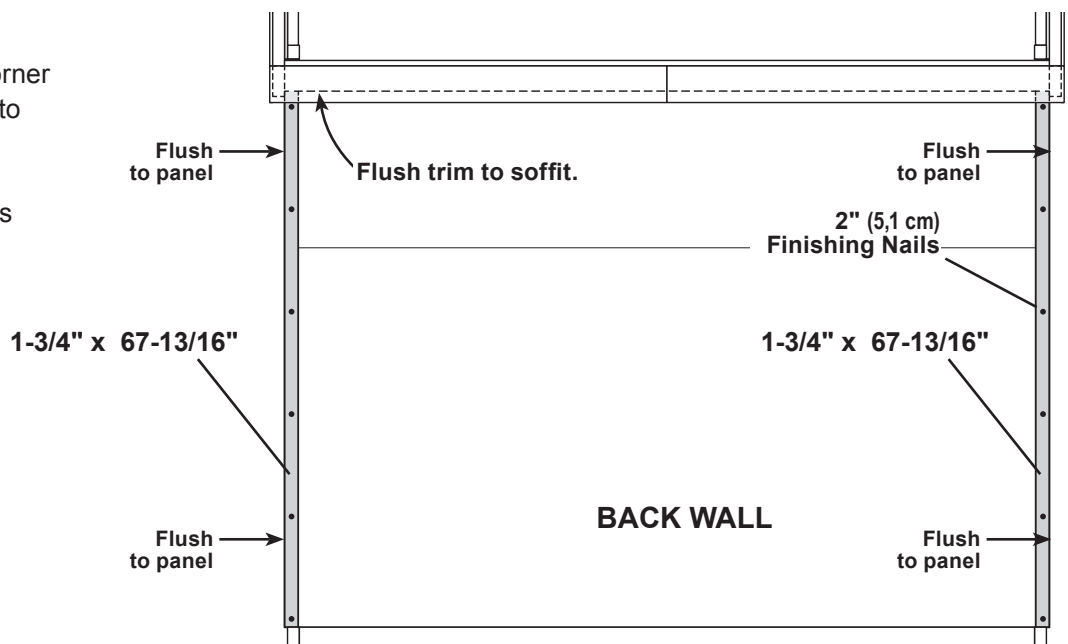

Your front and back corner trim is now installed.



# DOORS

## PARTS REQUIRED:

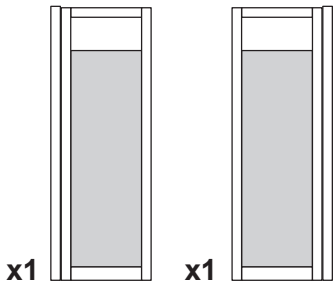

x1 **OO** Temporary Support

69" (175,3 cm) Door Stiffener

x1 **WFB** Temporary Support

3/8" x 5-1/2" x 18-5/8" (1,0 x 14 x 47,3 cm)

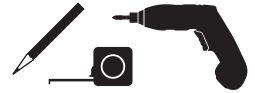
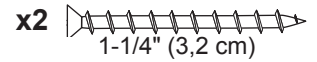
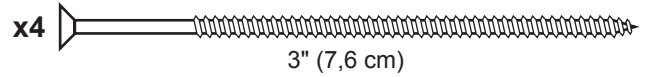

### ✓ BEGIN

**1** Arrange doors as shown, on flat surface. Ensure that the 3/8" offset is to top.

Look for red (right) and green (left) on hinge board.

Install temporary supports **OO** and **WFB**, as shown.

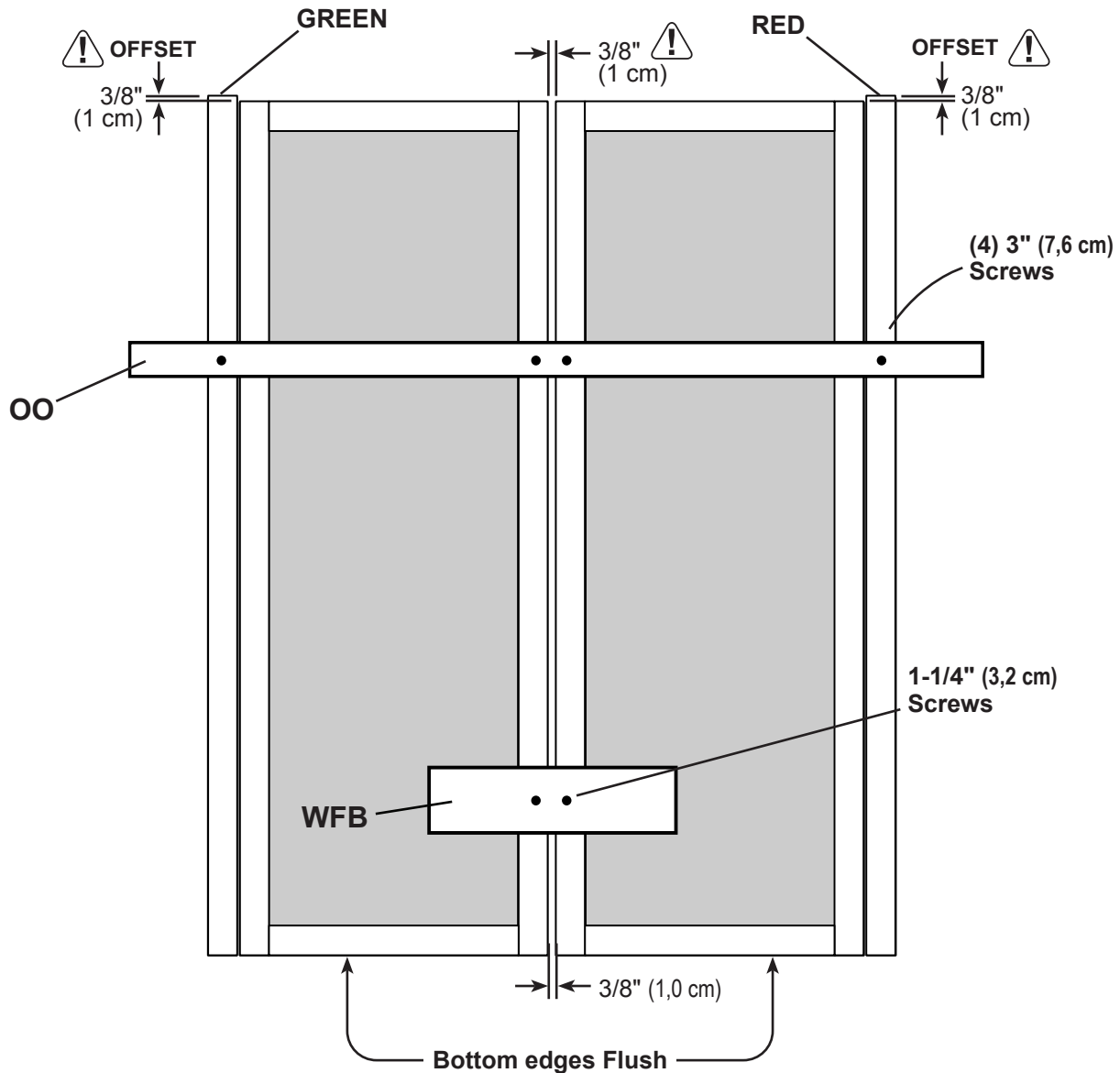

# DOORS

## PARTS REQUIRED:

x1  *Temporary Support*  
 3/8" x 1-3/4" x 68" (1,0 x 4,4 x 172,7 cm)

x1  *Temporary Support*  
 69" (175,3 cm) Door Stiffener

x12  3" (7,6 cm)



- 2** Install **OO** and (1) **3/8" x 1-3/4" trim piece** flush under wall panels.  
 Secure **OO** to floor frame with (2) 3" screws (**Fig. A**).

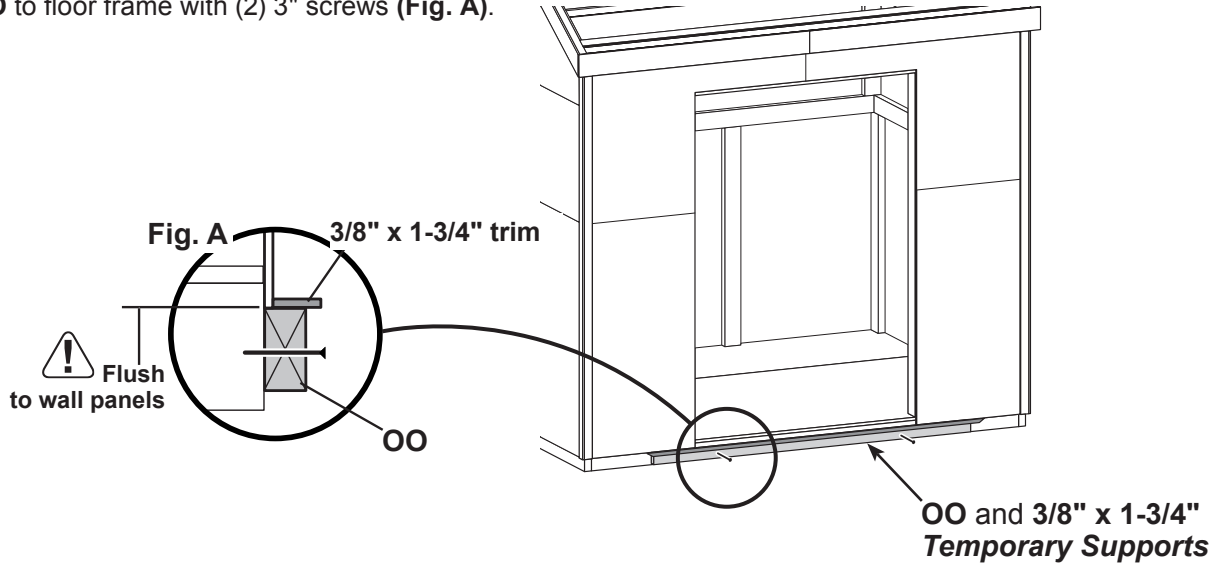

- 3** Center doors on the panel seam, as shown (**Fig. B**).  
 Secure hinge boards to door studs with (10) 3" screws.

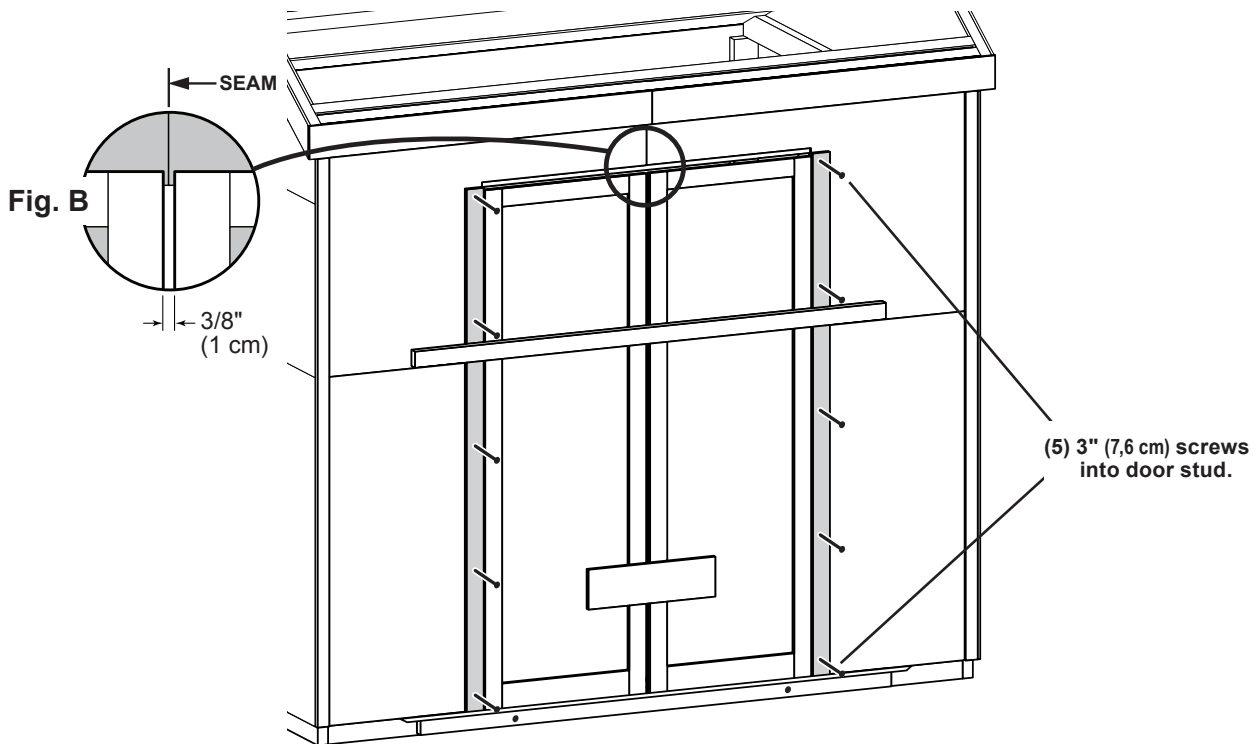

**Remove temporary supports and ensure that the doors open and close properly.**



You have finished installing your doors.

# DOOR TRIM

## PARTS REQUIRED:

x2

**WFB**

3/8" x 5-1/2" x 18-5/8" (1,0 x 14 x 47,3 cm)

x38   
3/4" (1,9 cm)



✓ **BEGIN**

- 1** Install (2) door rails **WFB** level and at measurement shown.  
Secure with 3/4" screws from inside of doors.
- 2** Reinforce the door trim with 3/4" screws through door panel into trim (**Fig. A**).  
Locate screws in the pattern shown (**Fig. B**).

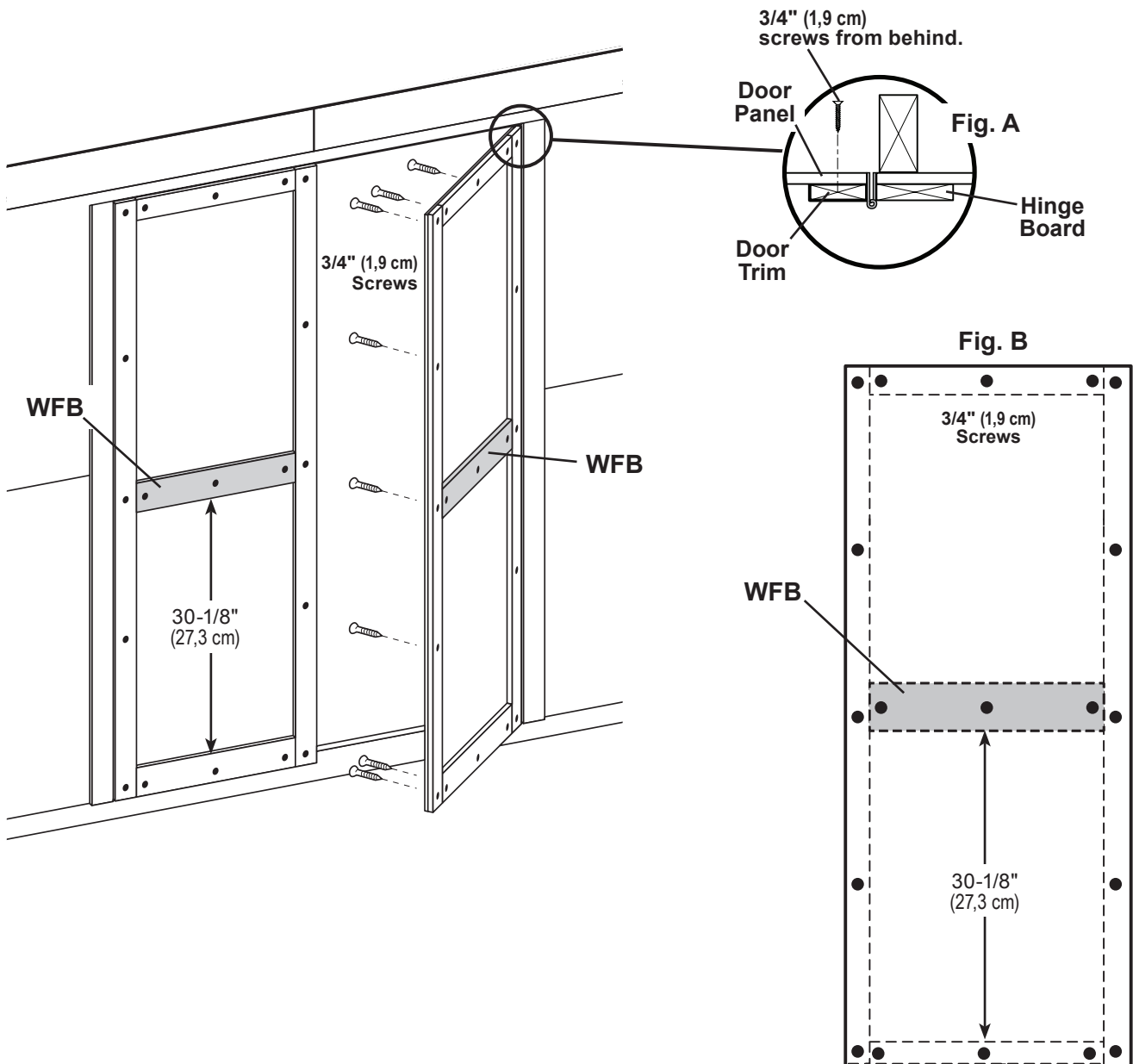

Your door trim is now installed.

## OVER DOOR TRIM and THRESHOLD

### PARTS REQUIRED:

x1 **JSA**  
3/8" x 1-1/2" x 54-9/16" (1,0 x 3,8 x 138,6 cm)

x1 **48" Metal Threshold**  
3/4" (1,9 cm) x9  
Bagged separately / special coating

x5 **2" (5,1 cm)**



### ✓ BEGIN

- 1 Center over door trim **JSA** over doors.  
Secure with (4) 2" finishing nails into framing.

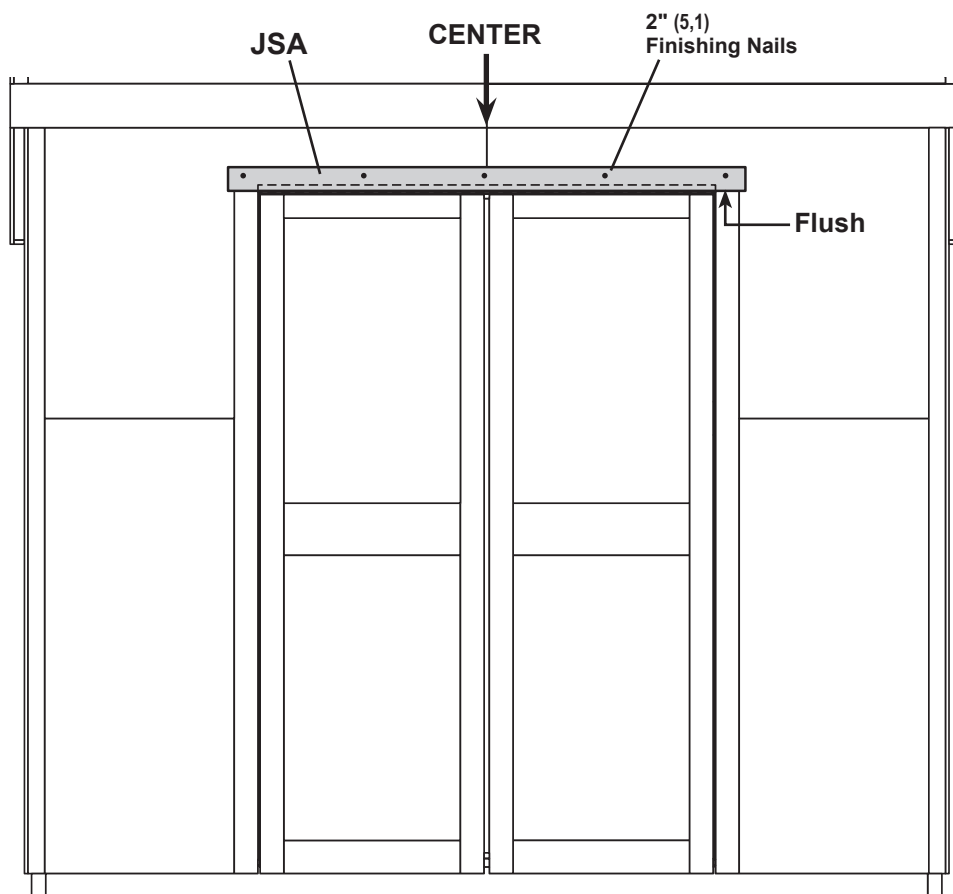

- 2 Center metal threshold between doors and secure with (9) 3/4" special coating screws into floor.

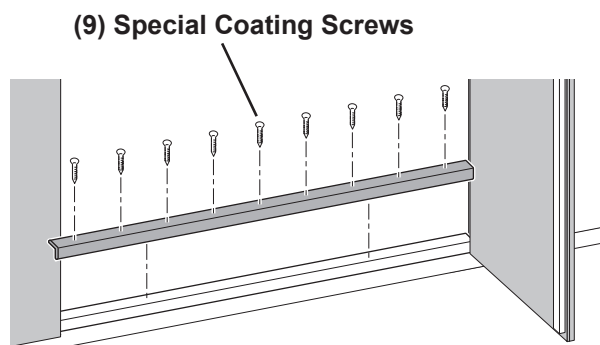

Your over door trim and threshold are now installed.

# DOOR STIFFENERS

## PARTS REQUIRED:

x2 **OO**  
69" (175,3 cm) Door Stiffener

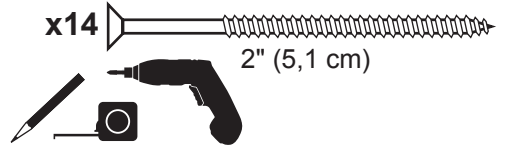

### ✓ BEGIN

- 1 Center (2) door stiffeners **OO** vertically on each door, as shown (Fig. A, Fig. B).  
Secure with (7) 2" screws through outside trim into **OO** (Fig. B).

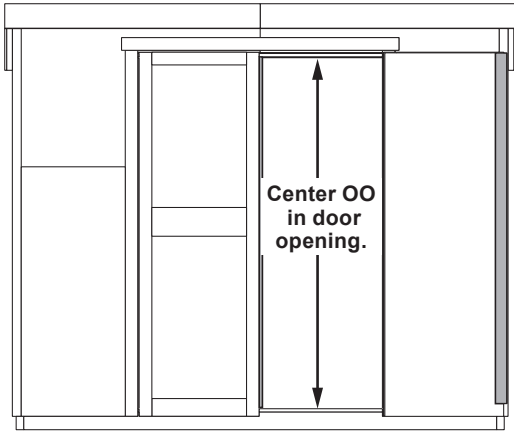
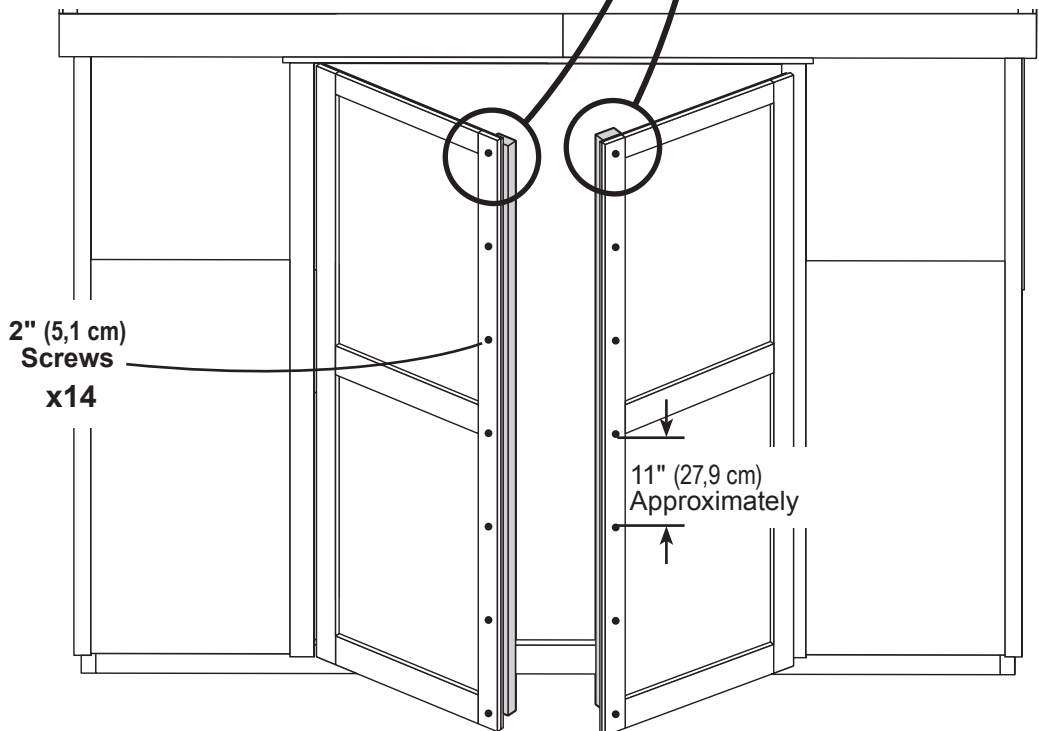
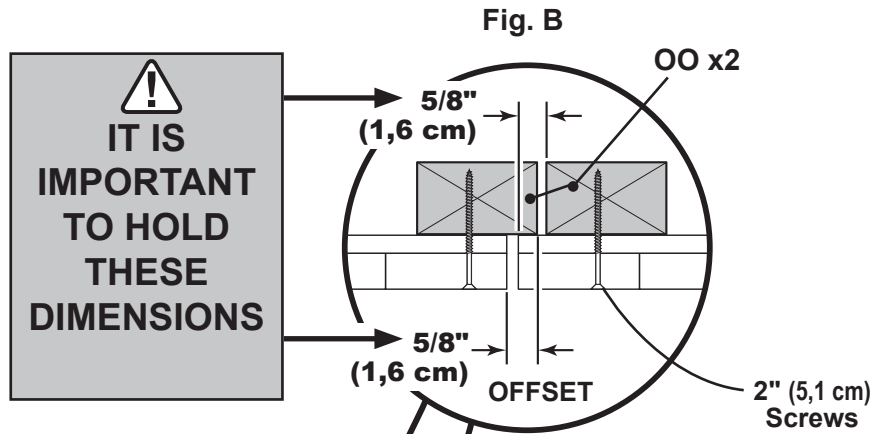

Fig. A



Your door stiffeners are now installed.

# DOOR HARDWARE

## PARTS REQUIRED:

x1

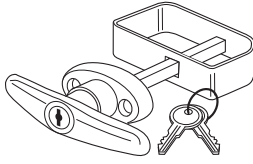

x2

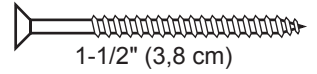

### ✓ BEGIN

**1** Measure and mark position on right door as shown.  
Pre-drill 1/4" hole at mark. Finish hole using 1/2" drill bit.

**2** Position hardware in hole and secure with screws as shown.

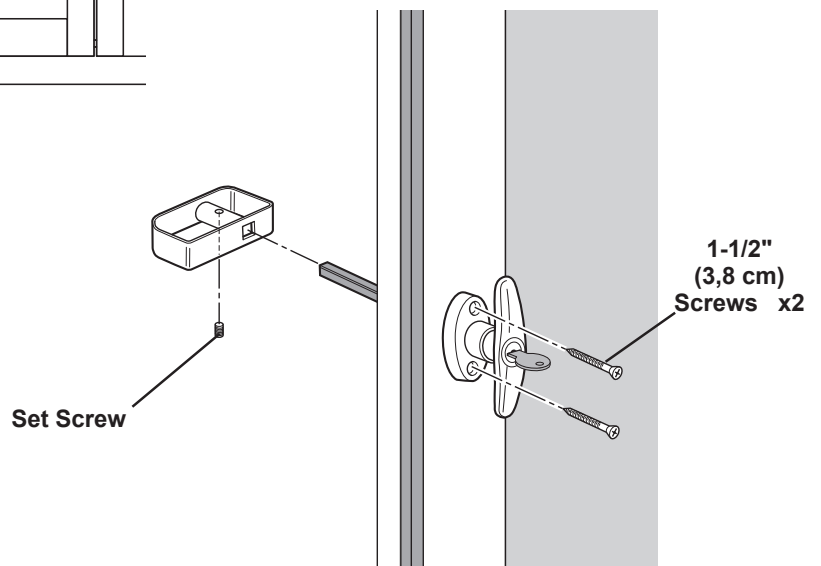
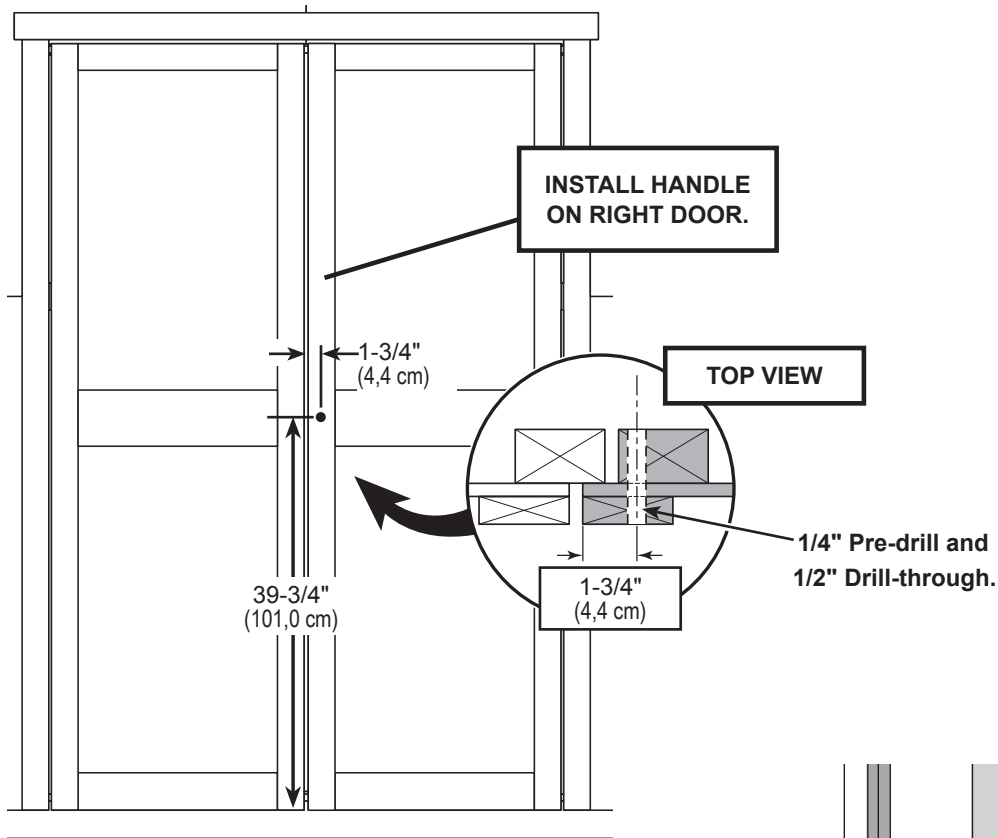

FINISH

Your door handle is now installed.

# DOOR HARDWARE

## PARTS REQUIRED:

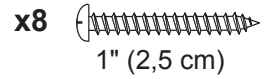
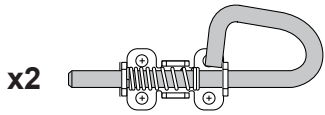

5/16" (0,8 cm) Drill Bit

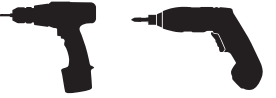

### ✓ BEGIN

- 1 Place spring bolt onto **OO** in open position with bolt end 3/8" down from frame. Bolt is open when loop is contacting base (**Fig A**).

Mark and pre-drill holes for screws.

- 2 Install bolt with screws supplied and drill 5/16" hole for bolt to extend into.

- 3 Place bolt onto **OO** in open position with bolt end 1/2" up from floor. Bolt is open when loop is contacting base (**Fig B**).

Mark and pre-drill holes for screws.

- 4 Install bolt with screws supplied and drill 5/16" hole for bolt to extend into.

Fig. A

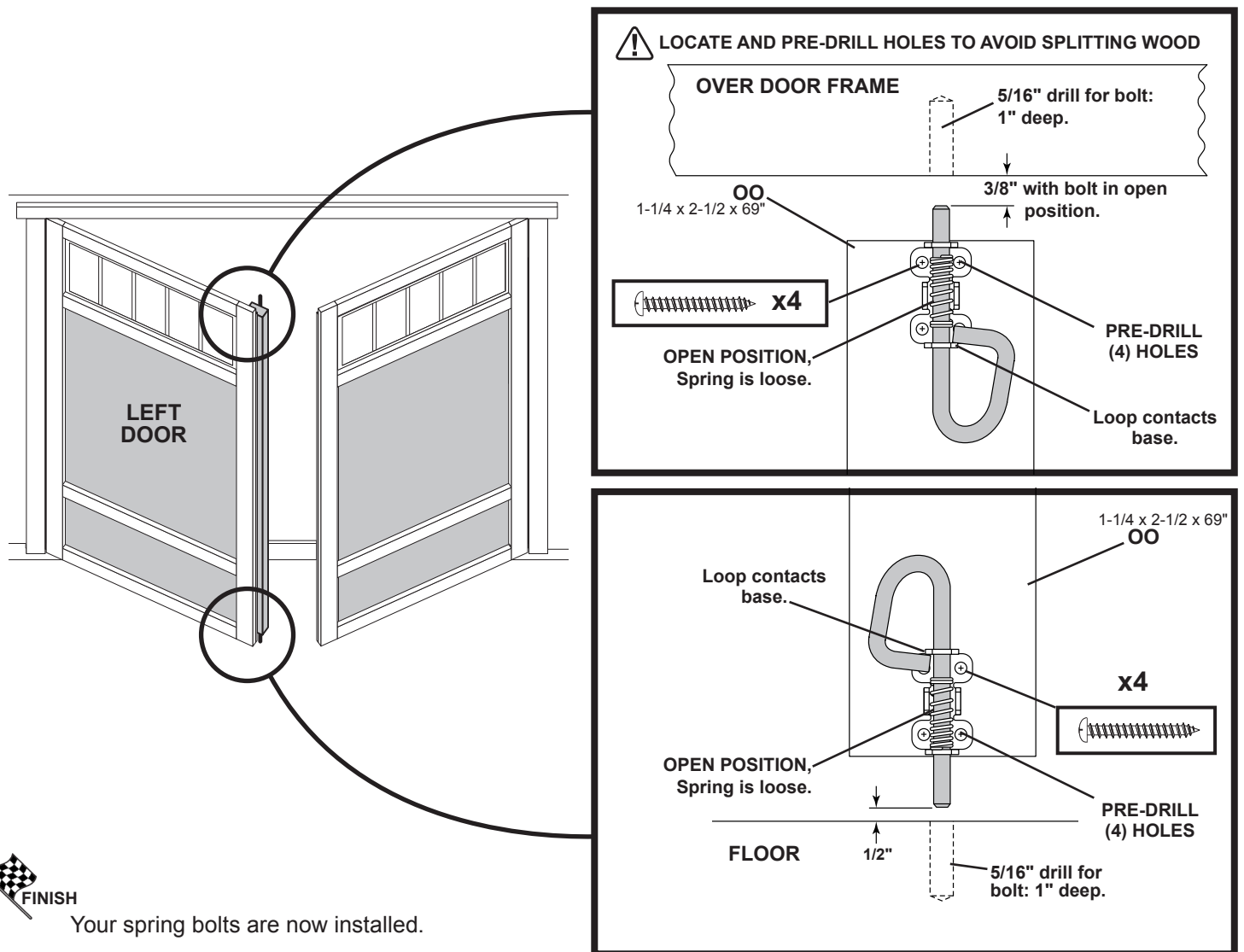





FINISH

Your spring bolts are now installed.

Fig. B

## RIGHT & LEFT SIDE TRIM

### PARTS REQUIRED:

- x1  3/8" x 1-3/4" x 68" (1,0 x 4,4 x 172,7 cm)
- x1  3/8" x 1-3/4" x 68" (1,0 x 4,4 x 172,7 cm)
- x1  3/8" x 1-3/4" x 80-7/16" (1,0 x 4,4 x 204,3 cm)
- x1  3/8" x 1-3/4" x 80-7/16" (1,0 x 4,4 x 204,3 cm)

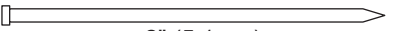
x26  2" (5,1 cm)



*Install trim with the primed side facing out.*

**BEGIN**

- 1 Install right side corner trim flush to soffit and flush to front and back wall panels. Secure with 2" finishing nails evenly spaced.

*Repeat for left side.*

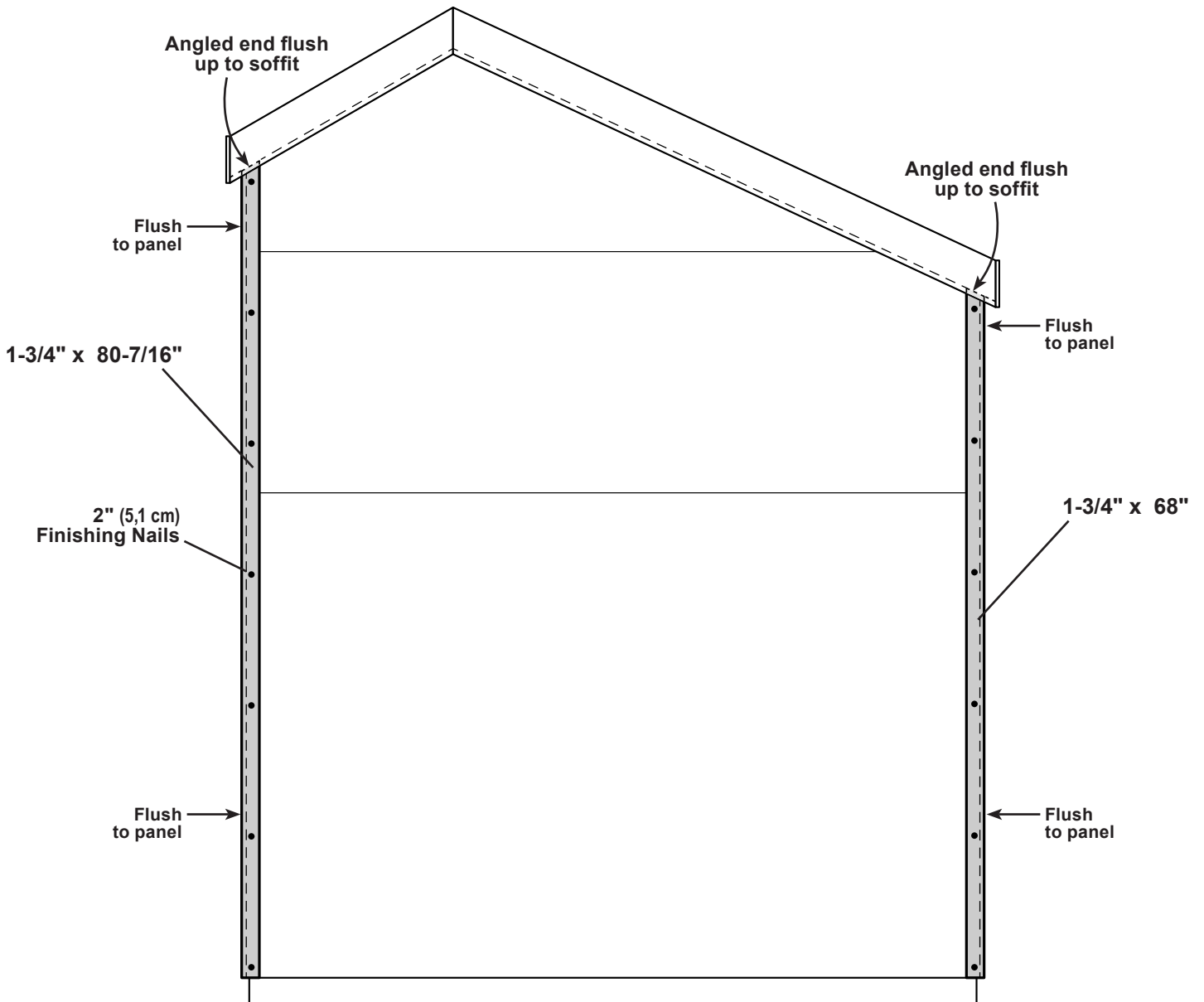



**ROOF PANELS**

**PARTS REQUIRED:**

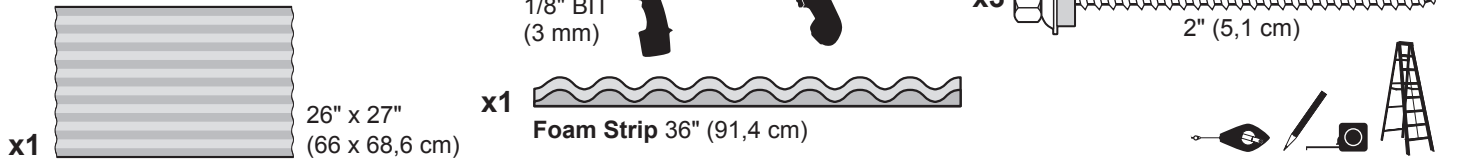

*Install all roof panels with the finished side up.*

**BEGIN**

**1**  
Use Fig. A as a measuring guide during roof panel installation.

Measure to centers of all purlins and overhang trim.  
Measurements are from ends of panels.

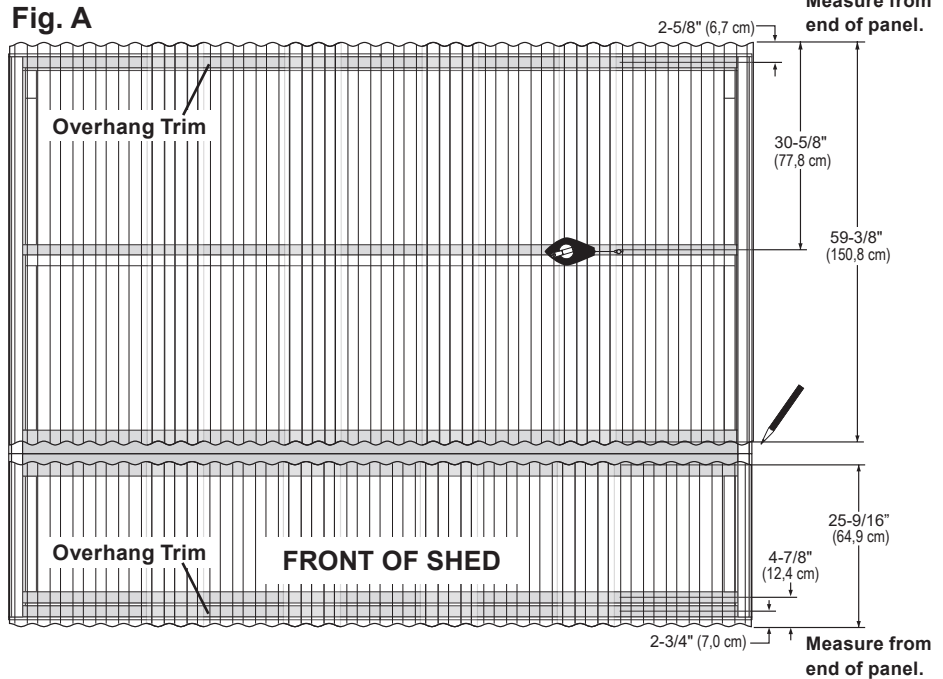

**2**  
Install the first 26" x 27" front roof panel overhanging edge of fascia trim by 1-1/2" and flush to edge of left side trim (Fig. B, Fig. C).

Install (1) foam strip flush along inner edge of overhang trim.

Install first 2" screw in the panel valley beginning at the left side of panel (Fig. B).

Install (2) additional screws in the 3rd and 5th valleys, as shown.  
Center screws in framing.

**Predrill all holes.**

**CAUTION:**  
Do not stand or lean on roof panels.

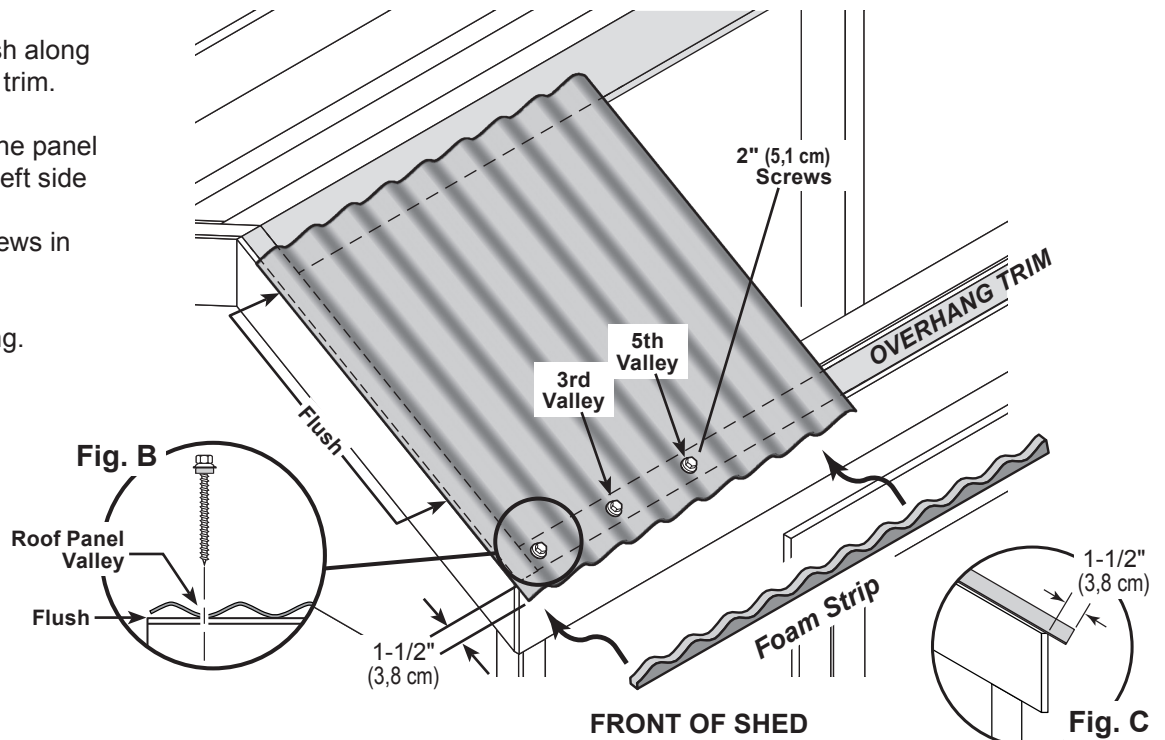

# ROOF PANELS

## PARTS REQUIRED:

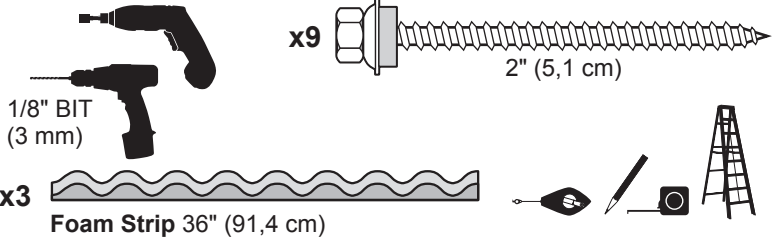
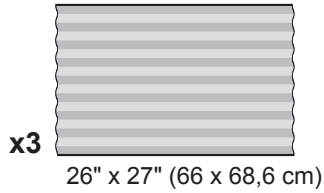

**3**

**Install roof panels with 3 overlapping countour waves covering the installed panel.**

Install 3 additional panels overlapping each installed panel by 3 panel contour waves (**Fig. D**) and overhanging front of fascia trim by 1-1/2".  
Flush panels along 1-1/2" overhang.

Install foam enclosure strips between roof panels and front wall overhang trim.  
Flush foam strip along inner edge of overhang trim.  
Foam strips are longer than width of panel; adjust accordingly.  
**Ensure ends of foam strips are flush to installed foam strips.**

Secure panels to overhang trim with (3) 2" screws in each panel (**Fig. D**).  
Center screws in framing.

**Predrill all holes.**

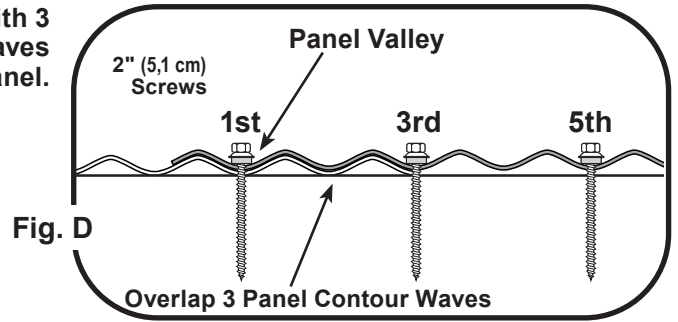

**CAUTION: Do not over-drive the screws; snug only!**

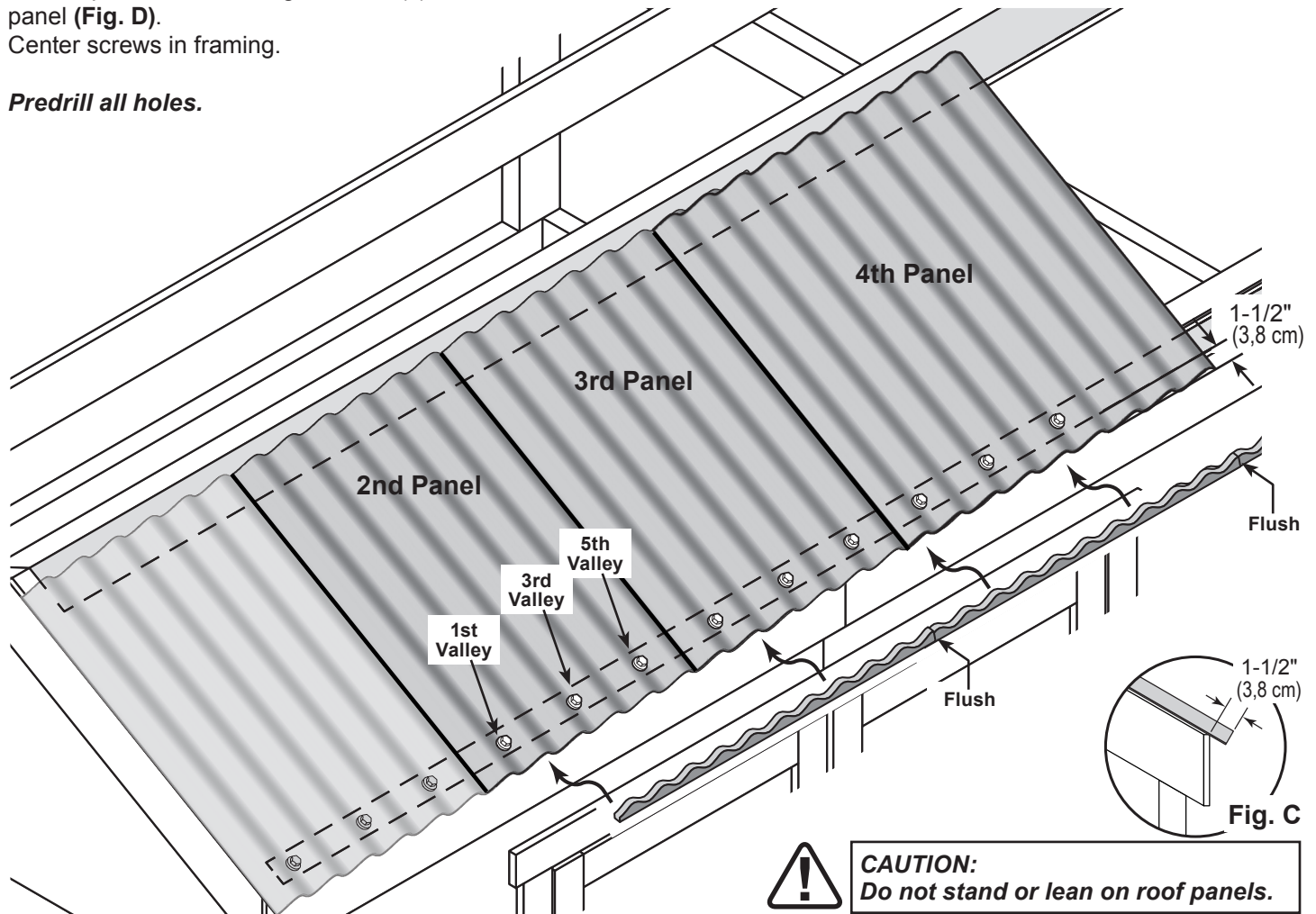

**CAUTION: Do not stand or lean on roof panels.**

# ROOF PANELS

## PARTS REQUIRED:

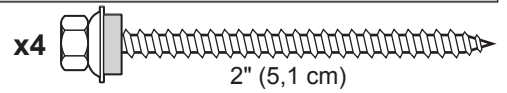
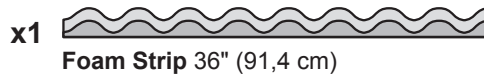
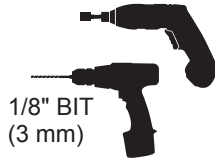
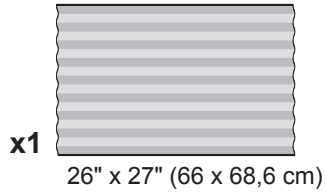

Install roof panels with 2 overlapping contour waves covering the installed panel.

4

Install 5th panel overlapping the 4th panel by 2 panel contour waves (Fig. E) and overhanging front of fascia trim by 1-1/2" (Fig. C).

Install foam enclosure strip between roof panel and front wall overhang trim.

**Ensure end of foam strip is flush to installed foam strip. Cut off excess.**

Secure panels to overhang trim with (4) 2" screws. Center screws in framing.

**Predrill all holes.**

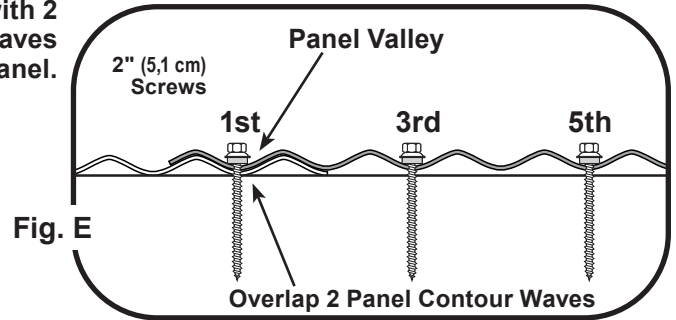

**CAUTION: Do not over-drive the screws; snug only!**

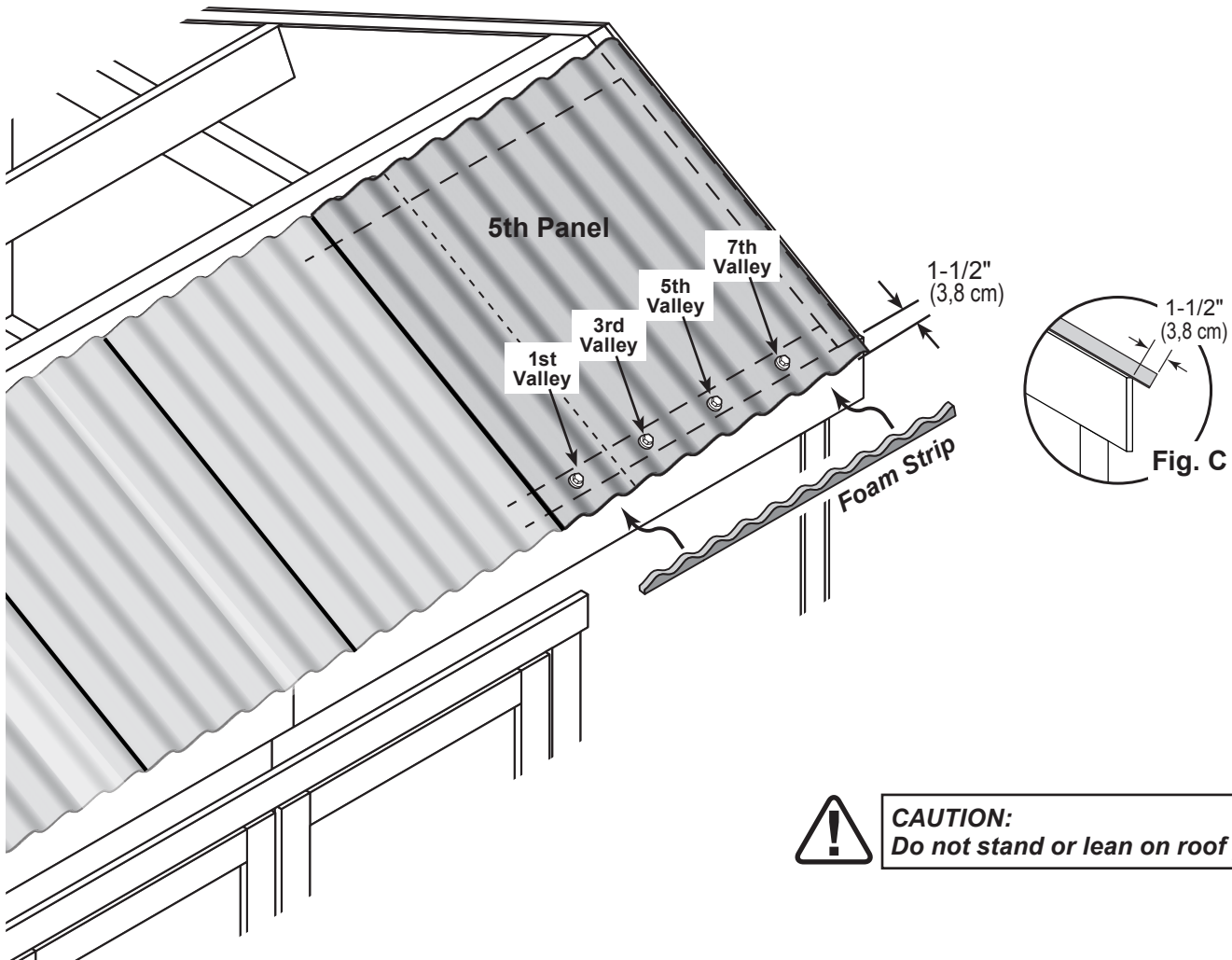

**CAUTION: Do not stand or lean on roof panels.**

## ROOF PANELS

### PARTS REQUIRED:

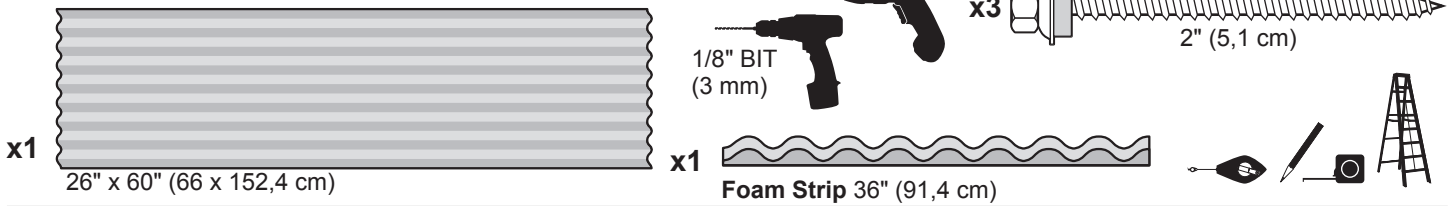

**5**

Install the first 26" x 60" back roof panel overhanging edge of fascia trim by 1-1/2" and flush to edge of right side trim (**Fig. B**, **Fig. C**).



**CAUTION:**  
Do not stand or lean on roof panels.

Install foam enclosure strip between roof panel and front wall overhang trim.

Install first 2" screw in the panel valley beginning at the right side of panel (**Fig. B**).

Install (2) additional screws in the 3rd and 5th valleys, as shown. Center screws in framing.

**Predrill all holes.**

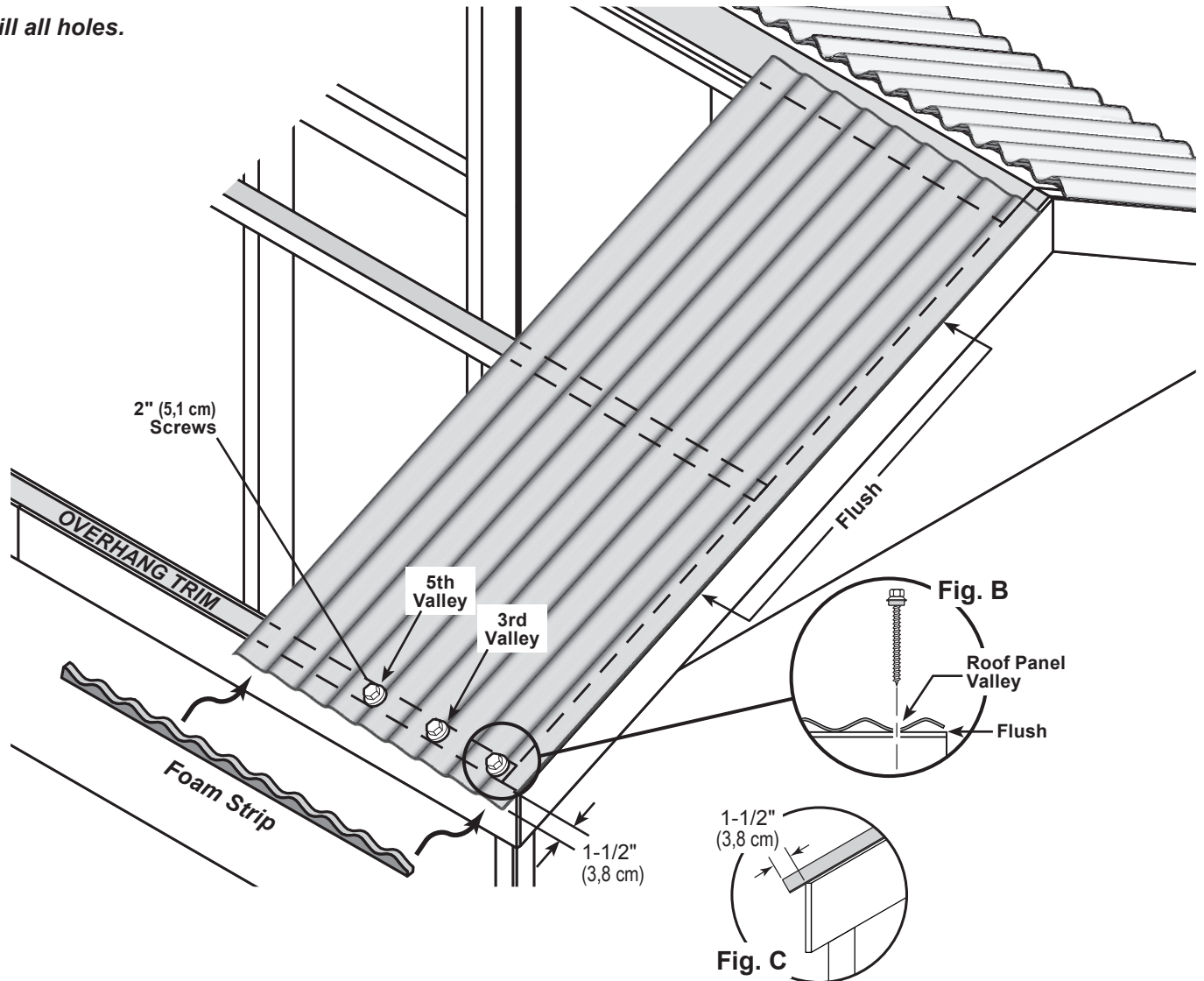



# ROOF PANELS

## PARTS REQUIRED:

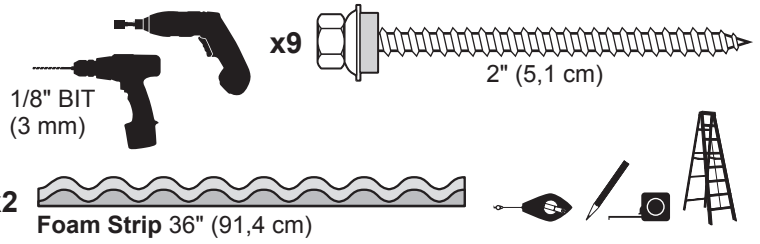
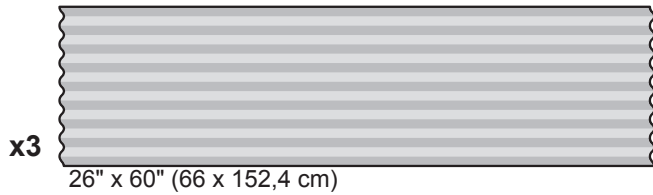

6

Install roof panels with 3 overlapping countour waves covering the installed panel.

Install 3 additional 60" panels overlapping each installed panel by 3 panel contour waves (Fig. D) and overhanging edge of fascia trim by 1-1/2" (Fig. C). Flush panels along 1-1/2" overhang.

Install foam enclosure strips between roof panels and front wall overhang trim. Flush foam strip along inner edge of overhang trim. Foam strips are longer than width of panel; adjust accordingly. **Ensure ends of foam strips are flush to installed foam strips.**

Secure panels to overhang trim with (3) 2" screws in each panel (Fig. D). Center screws in framing.

**Predrill all holes.**

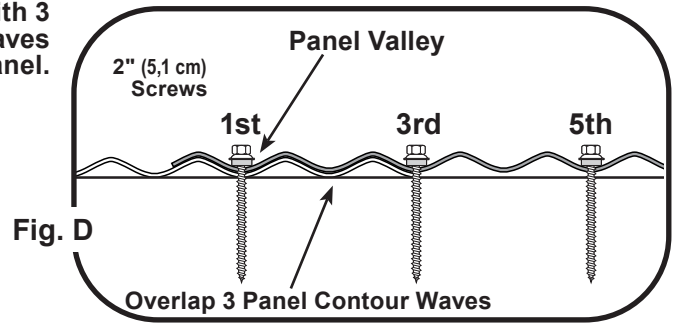

**CAUTION: Do not over-drive the screws; snug only!**

**CAUTION: Do not stand or lean on roof panels.**

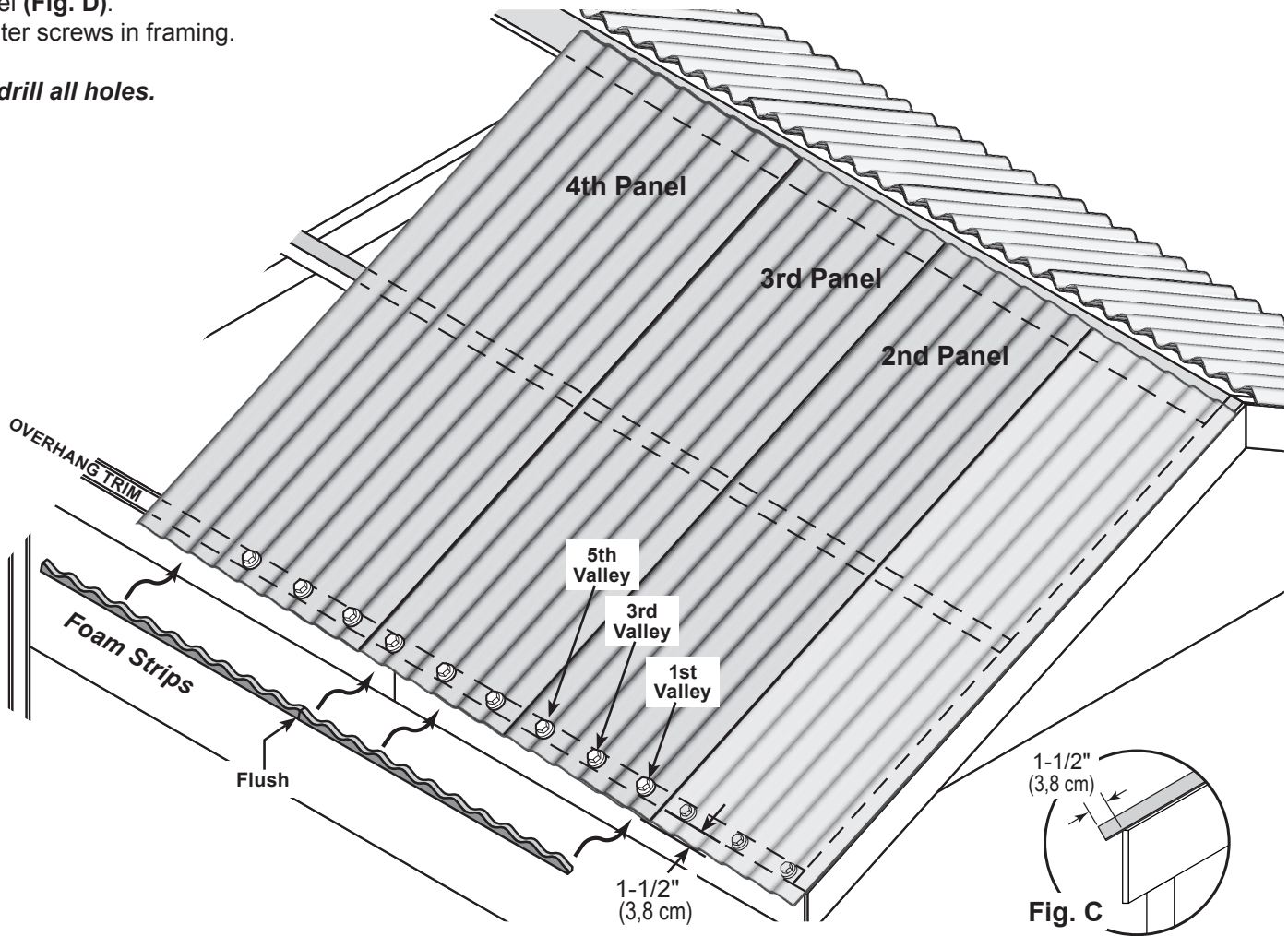

# ROOF PANELS

## PARTS REQUIRED:

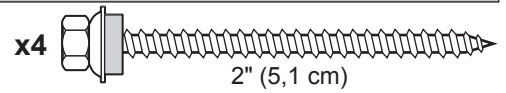
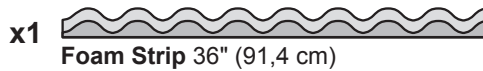
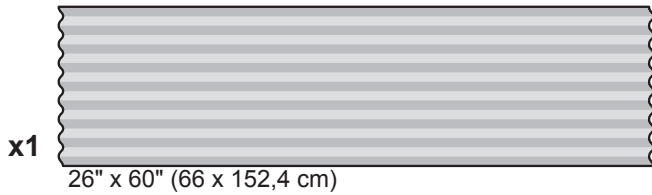

**7**

Install roof panels with 3 overlapping countour waves covering the installed panel.

Install 5th panel overlapping the 4th panel by 2 panel contour waves (Fig. E) and overhanging front of fascia trim by 1-1/2".

Install foam enclosure strip between roof panel and front wall overhang trim.

**Ensure end of foam strip is flush to installed foam strip. Cut off excess.**

Secure panels to overhang trim with (4) 2" screws (Fig. E). Center screws in framing.

**Predrill all holes.**

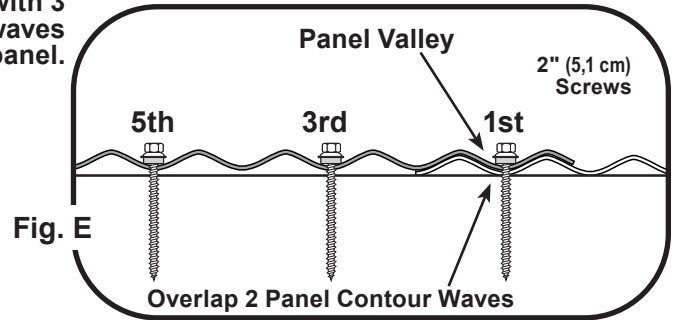

**CAUTION: Do not over-drive the screws; snug only!**

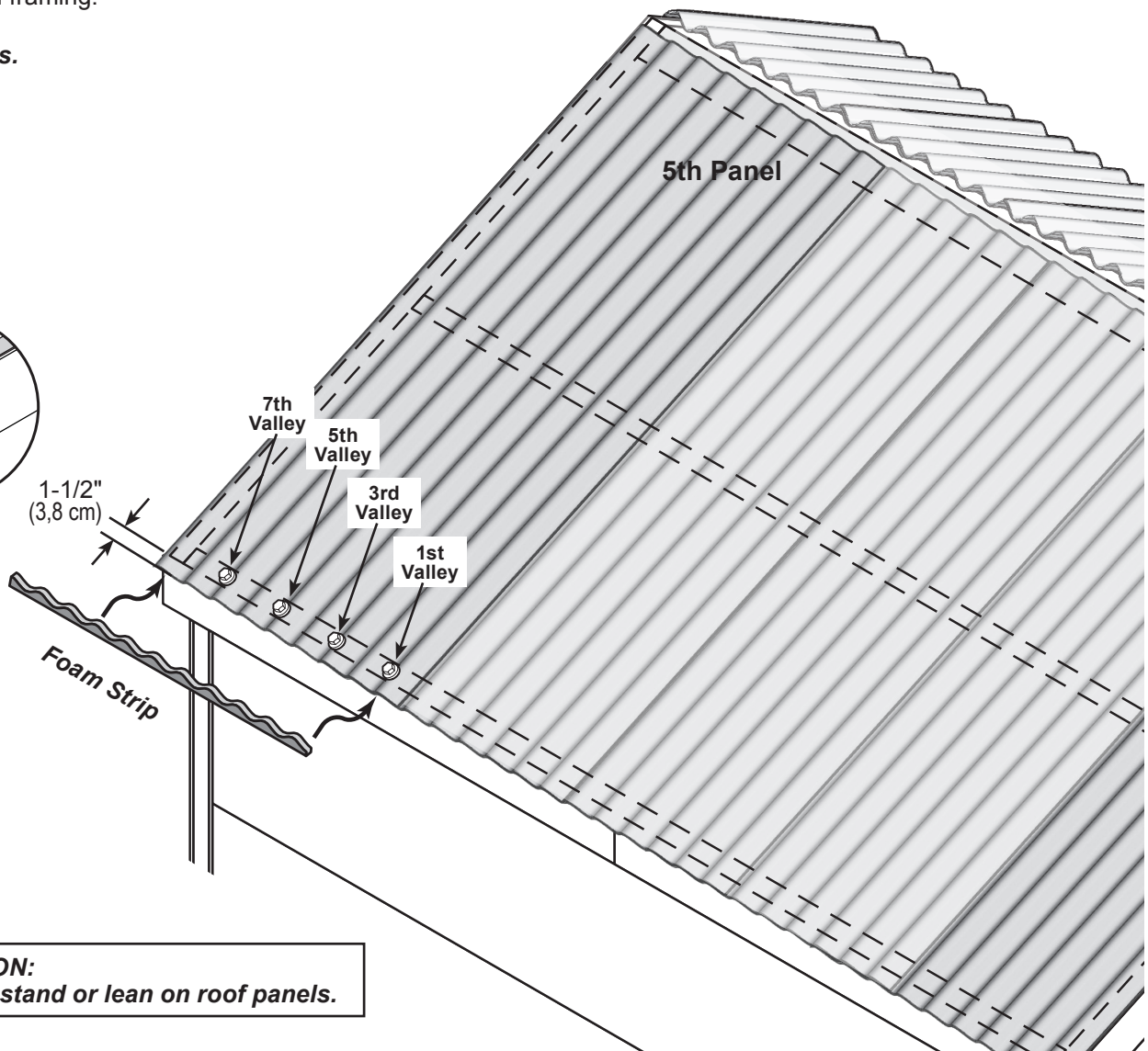
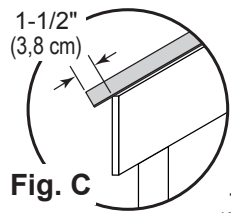



**CAUTION: Do not stand or lean on roof panels.**

# RIDGE CAP

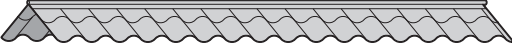
## PARTS REQUIRED:

x2  Ridge Cap 50" (127 cm)

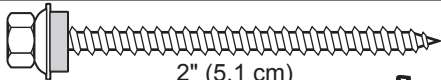
x2 or x3  RTV Silicone Tube  
Neutral Cure

x40  2" (5,1 cm)  
 1/8" BIT (3 mm)

### BEGIN

- 1 Measure and mark the center of the top roof purlins. Place (2) 50" ridge caps centered over roof panels and overlapping by one valley. Align all roof panel curves (front and back) to fit under curves of ridge cap.
- 2 Mark the front and back edges of ridge cap across all roof panels. Remove the (2) ridge caps. Apply a bead of RTV Silicone above the mark, along the entire marked edge, front and back sides of roof.
- 3 Reposition the ridge caps aligned over the roof panels, overlapping one valley. Working at the front of roof, install the first 2" screw in the center of the overlapping ridge cap valley. Ensure screw is located in lowest part of valley (**Fig. F**). Center screw in top purlin. **Predrill the screw hole.**
- 4 At the back side of ridge cap, install (1) 2" screw in the center of the overlapping ridge cap valley. Ensure screw is located in lowest part of valley (**Fig. F**). Center screw in top purlin. **Predrill the screw hole.**
- 5 Install 2" screws in every other ridge cap valley, across front and back sides of roof. Ensure screws are installed in lowest part of ridge cap valleys (**Fig. E**). **Predrill all holes.**

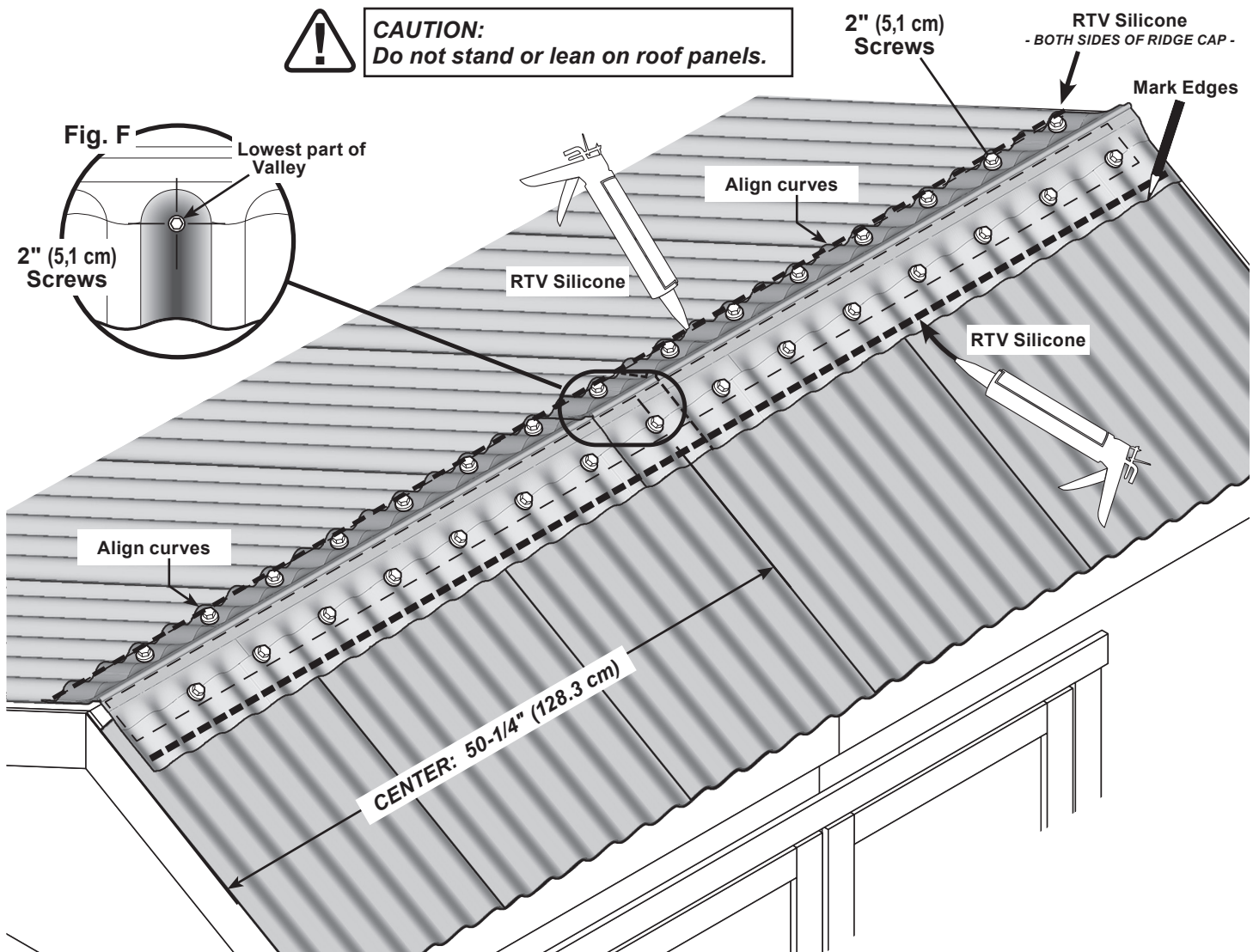



# ROOF PANELS

## PARTS REQUIRED:



6

Secure back panels to purlins and framing with 2" screws in panel peak (Fig. G).  
Center screws in framing.  
Panel Peak screw locations are shown as solid black.  
**Predrill all holes.**

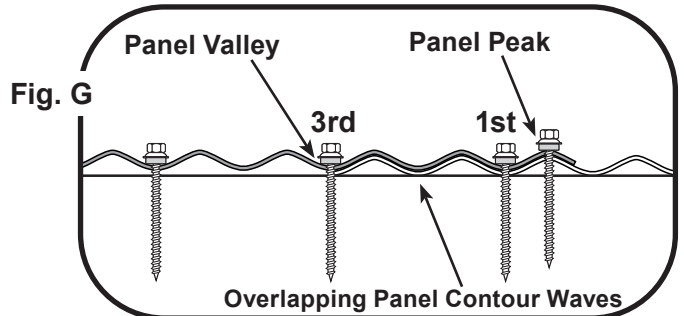

Secure panel to purlins and framing with 2" screws in each of the 1st, 3rd, 5th and 7th panel valleys, as shown, and as in (Fig. G).  
Center screws in framing.  
**Predrill all holes.**



**CAUTION: Do not over-drive the screws; snug only!**

7

Secure ridge caps to purlin with (1) 2" screw in 1st peak of overlap of ridge caps.  
Center screw in framing.  
**Predrill this hole.**

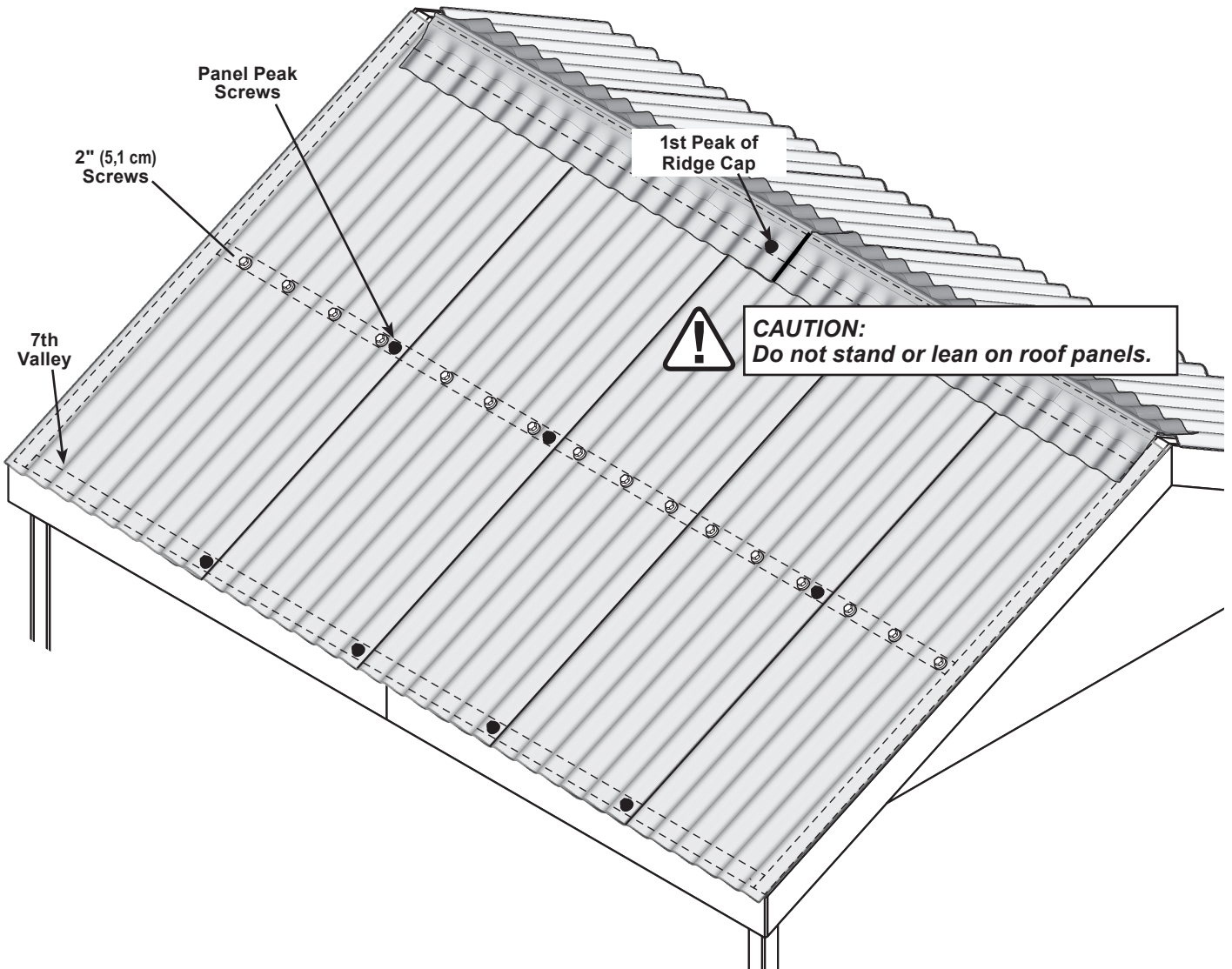

**CAUTION: Do not stand or lean on roof panels.**



## ROOF PANELS

### PARTS REQUIRED:



7

Secure front panels to purlins and framing with 2" screws in panel peaks (**Fig. G**). Center screws in framing.

*Predrill all holes.*

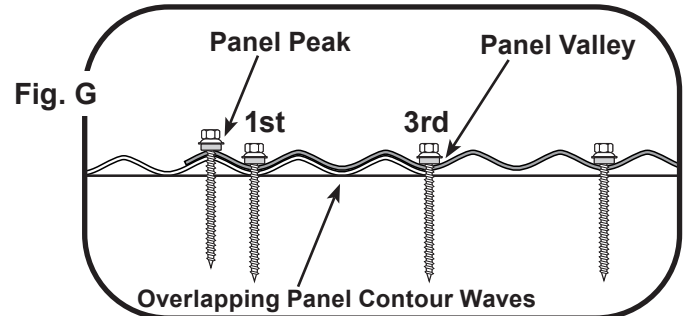

**CAUTION: Do not over-drive the screws; snug only!**

8

Secure ridge cap to purlin with (1) 2" screw in 1st peak of overlap of ridge caps. Center screw in framing.

*Predrill all holes.*

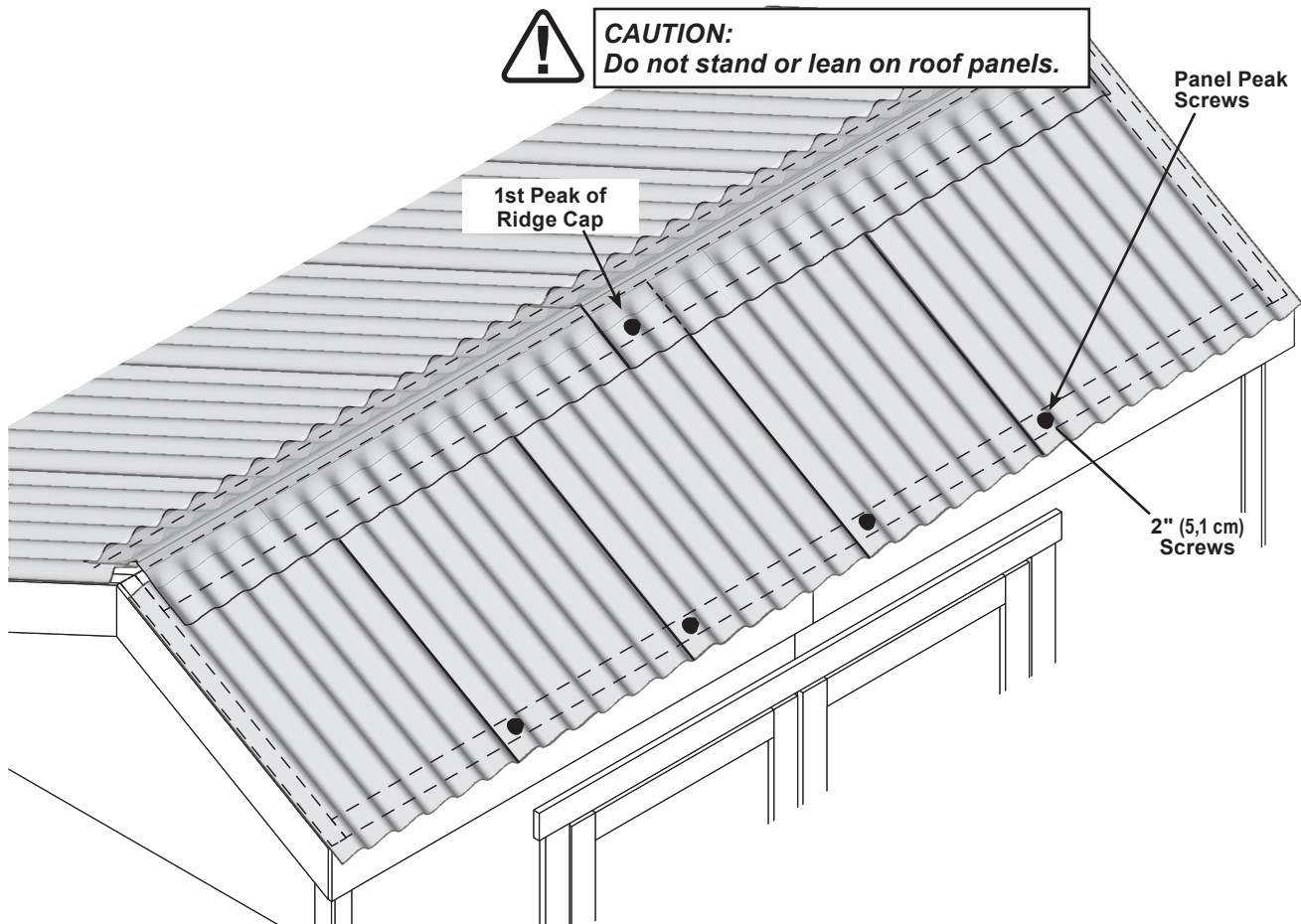

Your roof panels and ridge cap are now installed.

## RAKE FLASHING

### PARTS REQUIRED:

x2 or x3

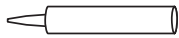
  
RTV Silicone Tube  
Neutral Cure



### ✓ BEGIN

- 1 Before installing Rake Flashing, it is important to fill and seal the hollow area between the flashing and the ridge cap at each end.

Use a generous amount of **Neutral Cure RTV Silicone** to completely fill the gap under flashing.

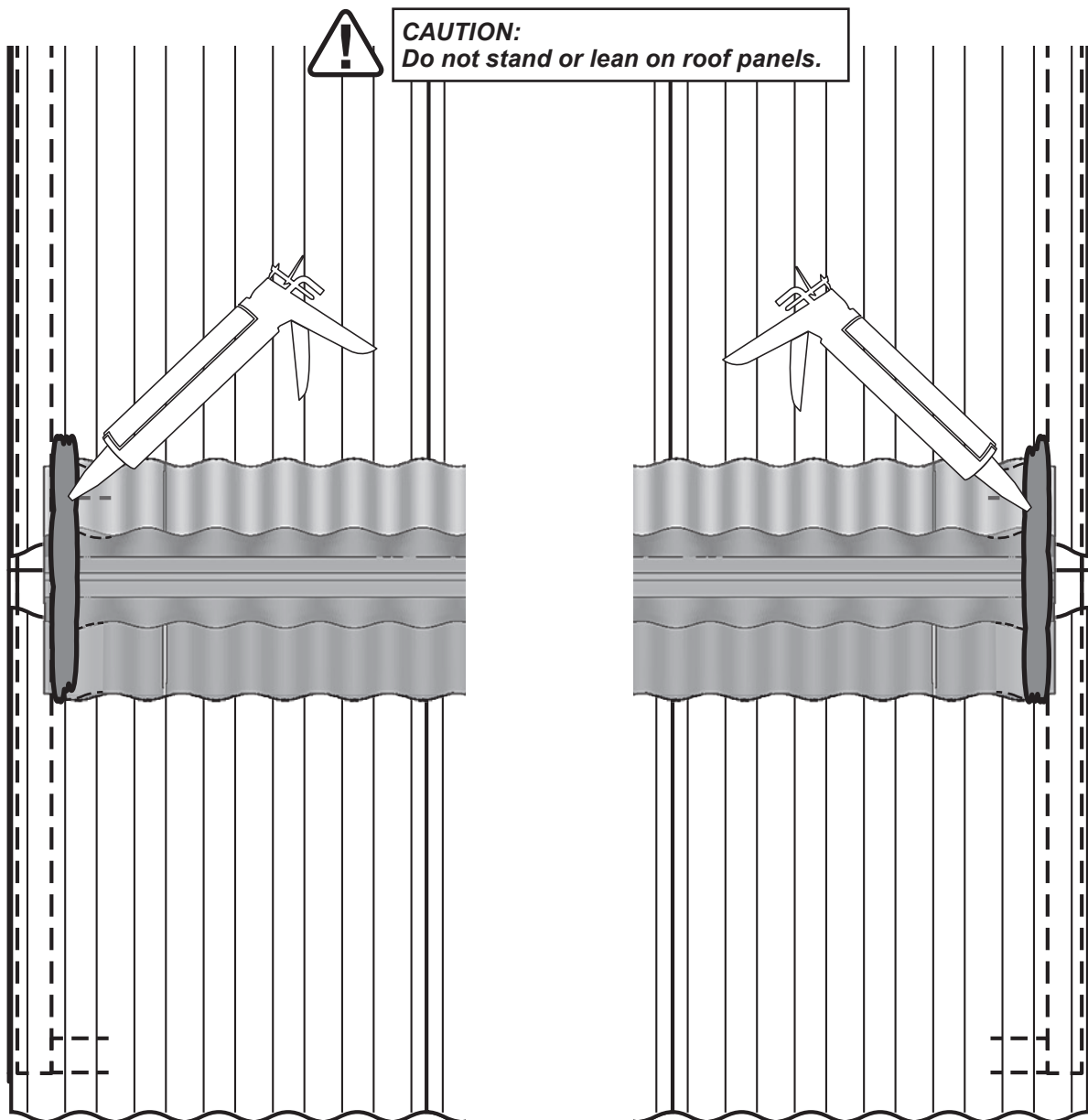

Follow sealant manufacturer's instructions for product use.

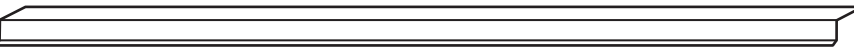

# RAKE FLASHING

## PARTS REQUIRED:

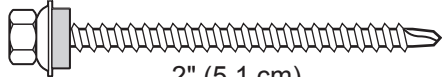
x2   
 Rake Flashing 15459 1-1/4" x 93" (3,2 x 236,2 cm)

x11  2" (5,1 cm)  
 1/8" BIT (3 mm)  

### 2 Rake flashing installation is the same for both sides of roof.

Measure, mark and trim 1-1/4" x 93" rake flashing (**Fig. A**, (**Fig. B**).  
 Right side and left sides shown.

Cut notch from flashing flange (**Fig. B**).

### 2

Begin installing at front of roof.  
 Flush the flashing to end of roof panel.  
 and flush to side fascia trim (**Fig. C**).  
 Bend rake over ridge cap.

Secure with 2" screws spaced approximately 8" apart.

**Start with top screws** 2" from roof peak.

Drive screws through the flashing and into the side trim framing (**Fig. C**).  
**Don't over-drive screws.**

Trim flashing flush to back panel.

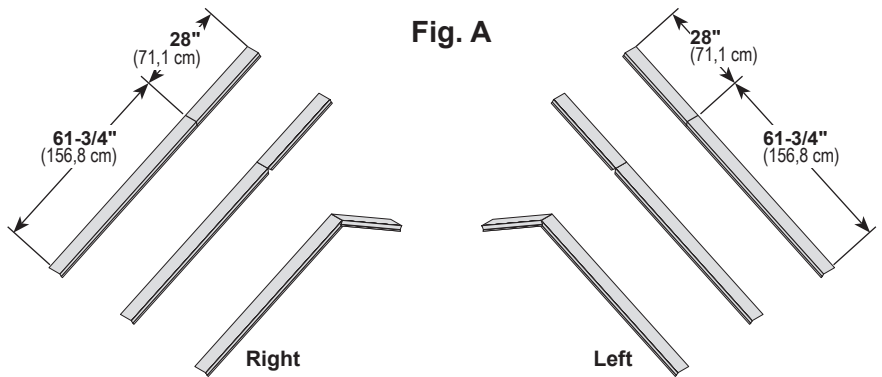

**HINT:** For an even bend, fold flashing over a 2x4.

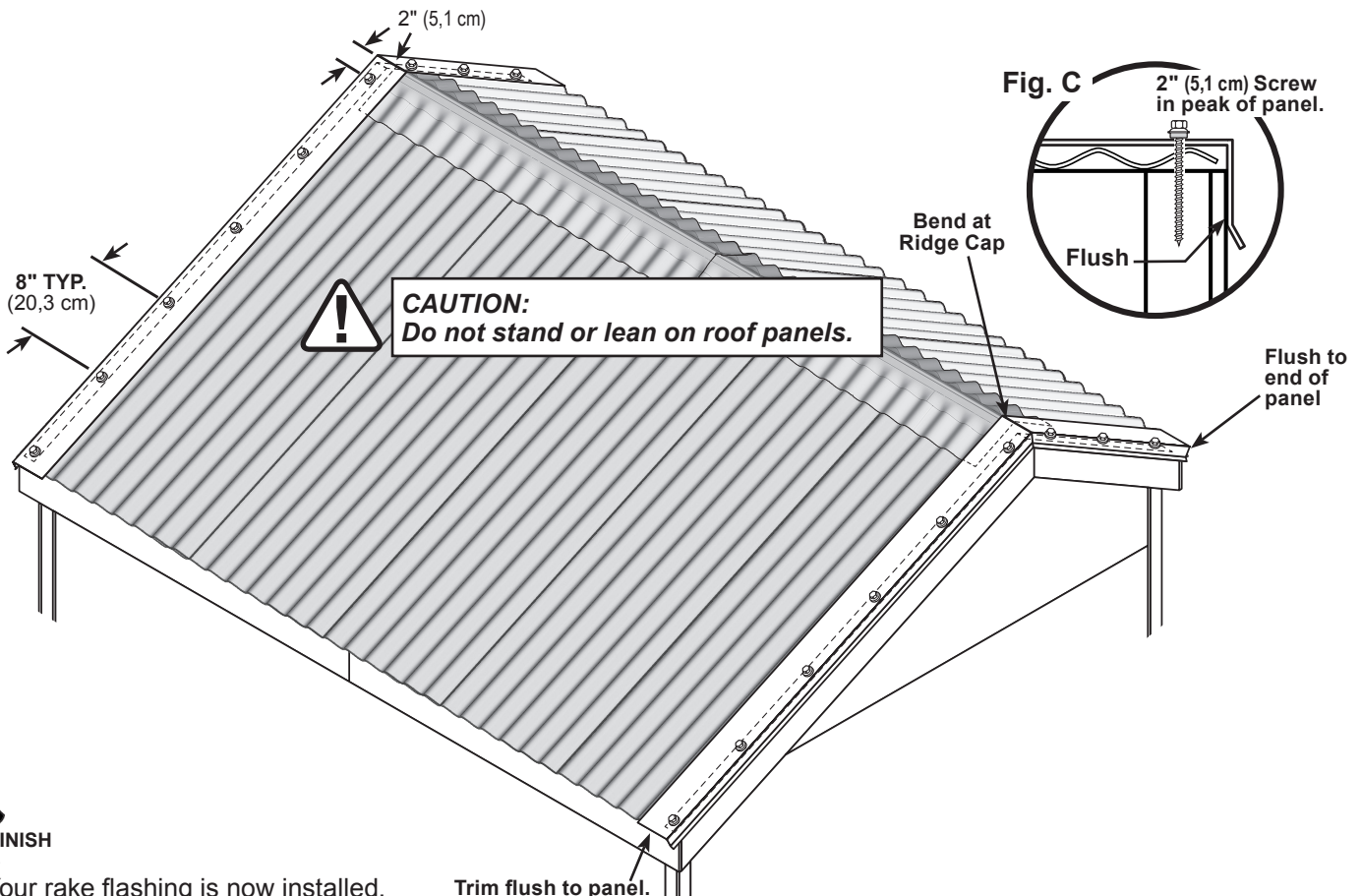
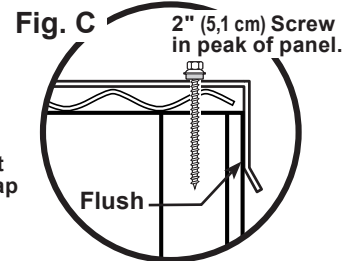
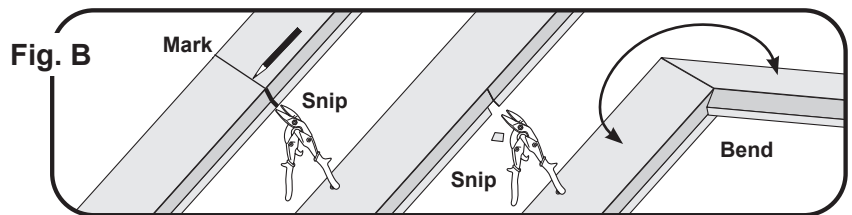

Your rake flashing is now installed.

Trim flush to panel.

# 16907 8' x 6' Order Form

CATEGORY	PART DESCRIPTION	PART SIZE	PART ITEM #	BUILDING QTY.	PART ID
<b>2 X 4</b>	Purlin	2 X 4 X 96-3/4"	O 9612000000	1	UXA
	Angled Purlin - Back	2 x 4 x 96-3/4" @ 25° BEVEL	O 9612000025	2	OTV
	Angled Purlin - Front	2 x 4 x 96-3/4" @ 30° BEVEL	O 9612000030	3	RTC
	Wall Brace - Upper	2 X 4 X 70-1/2" 25"	O 7008000025	2	RTJ
	Wall Brace - Side	2 X 4 X 69"	O 6900000000	2	PJ
	Wall Brace - Back	LUM SPF 2X4X96 #2&BTR	12306	1	TP
	Wall Brace - Front	2 X 4 X 22 1/2"	O 2208000000	2	AO
	Crippler	2 x 4 x 8-3/8"	O 0806000000	3	PHB
	Wall Stud - Lower	2 X 4 X 44-3/4"	O 4412000000	8	DMC
	Wall Stud - Upper Back	2 X 4 X 20 3/8" DOUBLER	O 2006000000	2	JBD
	Wall Stud - Upper Front	2 X 4 X 32" DOUBLER	O 3200000000	2	SC
	Door Frame	2 X 4 X 70-3/8"	O 7006000000	2	SHR
	Door Header	2 X 4 X 51" PLATE	O 5100000000	1	TCA
	Overhang - Long	2 X 4 X 59-1/4" 65"	O 5904000065	2	TKB
	Overhang - Short	2 X 4 X 25-1/2" 60"	O 2508000060	2	UNB
	<b>2 X 4 TREATED FLOOR FRAME</b>	Floor Joist	LUM TRTD 2 X 4 X 93 #2&BTR	P 9300000000	4
Floor Frame		LUM TRTD 2 X 4 X 72 #2&BTR	P 7200000000	2	---
<b>5/8 OSB</b>	Floor Panel - Large	OSB 5/8" X 4' X 8'	11117	1	---
	Floor Panel - Small	5/8" OSB 23 7/8" X 96" FLOOR	E 96002314000	1	---
<b>NO GROOVE SIDING</b>	Wall Panel - Lower Side	SIDING NGSE 3/8X4'X6'	11509	2	---
	Wall Panel - Lower Back	SIDING NGSE 3/8X4'X8'	11508	1	---
	Wall Panel - Lower Front	NG 23 7/8" X 48" WALL PANEL	K 48002314000	2	---
	Wall Panel - Upper Back	3/8" NG 23-11/16" X 96"	K 96002311000	1	---
	Wall Panel - Upper Side	3/8"NG 23 7/8" X72" PANEL OR	K 72002314000	2	---
	Wall Panel - Upper Front Left	3/8" NG 36-3/16" X 48" LFT PAN	K 48003603200	1	---
	Wall Panel - Upper Front Right	3/8" NG 36-3/16" X 48" RGT PAN	K 48003603100	1	---
	Gable Panel Left	3/8" NG 22-11/16" X 72" LFT GAB	K 72002211200	1	---
	Gable Panel Right	3/8" NG 22-11/16" X 72" RGT GAB	K 72002211100	1	---
	Fascia - Front/Back	3/8" NG 4-5/8" X 50-1/4"	K 50040410000	4	---
	Fascia - Left Long	3/8" NG 4-3/16" X 59-1/4" 65" LFT	K 59040403265	1	---
	Fascia - Left Short	3/8" NG 4" X 25-1/2" 60" LFT	K 25080400260	1	---
	Fascia - Right Long	3/8" NG 4-3/16" X 59-1/4" 65" RGT	K 59040403165	1	---
	Fascia - Right Short	3/8" NG 4" X 25-1/2" 60" RGT	K 25080400160	1	---
	Soffit - Front/Back	3/8" NG 1-1/2" X 48-3/8"	K 48060108000	4	---
	Soffit - Side Long	3/8" NG 1-1/2" X 59-1/16"	K 59010108000	2	---
	Soffit - Side Short	3/8" NG 1-1/2" X 25-1/4"	K 25040108000	2	---
	Door Panel	3/8" NG 23 3/8" X 71 1/2" DOOR PANEL	K 71082306000	2	---
	Vertical Trim - Front Left	3/8" NG 1-3/4" X 80-7/16" 30" LFT	K 80070112200	1	---
	Vertical Trim - Front Right	3/8" NG 1-3/4" X 80-7/16" 30" RGT	K 80070112100	1	---
	Vertical Trim - Front	3/8" NG 1-3/4" X 80-1/4"	K 80040112000	2	---
	Vertical Trim - Back Left	3/8" NG 1-3/4" X 68" LFT	K 68000112200	1	---
Vertical Trim - Back Right	3/8" NG 1-3/4" X 68" RGT	K 68000112100	1	---	
Vertical Trim - Back	3/8" NG 1 3/4" X 67-13/16"	K 67130112000	2	---	
<b>19/32 X 3 SMART TRIM</b>	Over Door Trim	19/32 TST 2-1/2" X 54-9/16"	UT54090208000	1	JSA
	Door Trim Hinge	19/32 TST 2 1/2" X 72" TRIM	UT72000208000	2	ZJ
	Vertical Door Stile	19/32 TST 2 1/2" X 71 5/8"	UT71100208000	4	GY
	Top Horizontal Rail	19/32 TST 2 1/2" X 18-5/8" RAIL	UT18100208000	2	EGB
<b>19/32 X 4 SMART TRIM</b>	Bottom Horizontal Rail	19/32 TST 3-1/2" X 18-5/8"	UT18100308000	2	RIC
<b>19/32 X 6 SMART TRIM</b>	Door Rails	19/32 TST 5-1/2" X 18-5/8"	UT18100508000	2	WFB
<b>PURCHASED COMPONENTS</b>	Door Stiffener	LSL 1-1/4 X 2-1/4 X 69 PET	12715	2	OO
	Metal Hinge	HINGE PIANO 1 3/4"X71" GALV	15257	2	---
	Hinge Screws	SCREW #6-8 X 1" DEEP THREAD	15146	48	---
	Threshold	THRESHOLD 7/8 X 1-1/2 X 47-7/8	15422	1	---
	6D Nails	NAIL 6D 2" BOX HDG BOX	15105	3	---
	10D Nails	NAIL 10D 3" BOX HDG BOX	15109	1	---
	Handle	HANDLE - T 4" SHAFT & "D"	15375	1	---
	Hardware kit	H/K (33258) 8X6 MELBOURNE	15737	1	---
	Palram 2" Screws	EPDM Washered Fasteners Palram 2"	15598	3	---
	Palram Roof Short	PALRAM SUNTOP PANEL 27" x L 26" W	15756	5	---
	Palram Roof Long	PALRAM SUNTOP PANEL 60" x L 26" W	15757	5	---
	Foam Strip	BAG OF (QTY. 5) HORIZONTAL CLOSURE STRIPS (FOAM)	15621	2	---
	Metal Rake Trim	1-1/4" x 4-1/2" x 93" RAKE	15459	2	---
Palram Ridge Cap	PALRAM SUNTOP RIDGE CAP 5.9" x 5.9" x 50"	15759	2	---	
<b>PACKAGING</b>	Instructions		16907	1	---

## LIMITED CONDITIONAL WARRANTY\*

Backyard Storage Solutions, LLC warrants the following:

1. Every product is warranted from defects in workmanship and manufacturing for 1 year.
2. All accessories, hardware and metal components are warranted for 2 years.
3. All Oriented Strand Board (OSB) is warranted for 2 years
4. Siding and Trim is warranted for 10 years.
5. Solar Shed windows are warranted for 1 year.
6. Cedar lumber is warranted for 15 years.
7. Preserved Pine is warranted for 10 years.
8. Redwood is warranted for 10 years.

Backyard Storage Solutions, LLC will repair, replace or pay for the affected part. In no event shall Backyard Storage Solutions, LLC pay the cost of labor or installation or any other costs related thereto. All warranties are from date of purchase. If a cash refund is paid on an affected part, it will be prorated from the date of purchase.

## CONDITIONS

The warranty is effective only when:

1. The unit has been erected in accordance with the assembly instructions.
2. The unit has been properly shingled and painted or stained and reasonably and regularly maintained thereafter.
3. The failure occurs when the unit is owned by the original purchaser.
4. Backyard Storage Solutions, LLC has received the warranty registration card within thirty (30) days of purchase and notification of the failure in writing within the warranty period specified above.
5. Backyard Storage Solutions, LLC has had reasonable opportunity during the sixty (60) days following receipt of notification to inspect and verify the failure prior to commencement of any repair work.

## REQUIREMENTS

### Storage Buildings

To validate your warranty, it is necessary to properly maintain your Backyard Storage Solutions, LLC unit; shingle the roof and paint or solid-colored stain the siding using quality, 100% acrylic latex exterior product with a minimum of two (2) coats within thirty (30) days of assembly; caulk above all doors and all horizontal and vertical trim boards; paint and seal all exposed edges, sides and faces of siding/trim and OSB siding to include all exterior walls and all sides and all edges of doors.

### Gazebos & Pergolas

To validate your warranty, it is necessary to properly maintain your Backyard Storage Solutions, LLC unit. This includes treating all of the exposed cedar and pine surfaces on your gazebo or pergola structure with an exterior grade wood preservative, an exterior oil-based semi-transparent stain, an acrylic latex exterior paint or an acrylic latex solid color exterior stain within 30 days of assembly and as needed thereafter to maintain your warranty.

Keep vegetation trimmed away from building and make sure siding panels and trim do not come in contact with masonry or cement. The minimum ground clearance for siding must be one half inch (½ inch) from concrete slab or two and one half inches (2 ½") from the ground when building is erected or constructed on a treated wood floor kit. Water from sprinklers must be kept off unit. In no event will Backyard Storage Solutions, LLC be responsible for any indirect, incidental, consequential or special damages nor for failure(s) that are caused by events, acts or omissions beyond our control including, but not limited to, misuse or improper assembly, improper maintenance (which eventually leads to rot or decay) and acts of God. Backyard Storage Solutions, LLC will not be held responsible for any labor costs incurred to construct your unit.

This warranty gives you certain specific rights that vary from state to state.

## CLAIM PROCEDURE

To make a claim under this warranty, you can either call 1-888-827-9056 or email: [customerservice@backyardproducts.com](mailto:customerservice@backyardproducts.com).

Please have ready the information below when you call or include the information in your email:

1. The model and size of the product.
2. A list of the part(s) for which the claim is made.
3. Proof of purchase of the Backyard Storage Solutions, LLC item, as shown on the original invoice or receipt.
4. Run code: found on exterior product label or assembly instructions enclosed in the product package.

All other inquiries can be mailed to:

Backyard Storage Solutions, LLC  
Attn: Customer Service  
1000 Ternes  
Monroe, MI 48162

**\*WARRANTY TERMS MAY VARY OUTSIDE THE U.S.A.**

**IMPORTANT: This is your warranty certificate.**

10Y MV LDR: 3/20/2019